

TECHNICAL MANUAL

OPERATOR'S, UNIT,  
DIRECT SUPPORT AND GENERAL  
SUPPORT MAINTENANCE  
MANUAL  
FOR

SHELTER, ELECTRICAL  
EQUIPMENT S-280C/G  
(NSN 5411-01-092-0892)

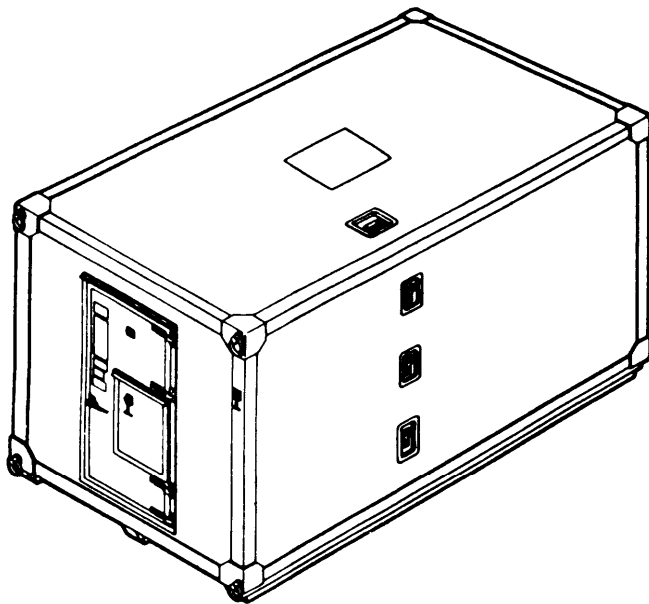

INTRODUCTION	1-1
OPERATING INSTRUCTIONS	2-1
UNIT MAINTENANCE INSTRUCTIONS	3-1
DIRECT SUPPORT MAINTENANCE INSTRUCTIONS	4-1
GENERAL SUPPORT MAINTENANCE INSTRUCTIONS	5-1
REFERENCES	A-1
MAINTENANCE ALLOCATION CHART	B-1
COMPONENTS OF END ITEM AND BASIC ISSUE ITEMS LISTS	C-1
EXPENDABLE/DURABLE SUPPLIES AND MATERIALS LIST	D-1

APPROVED FOR PUBLIC RELEASE: DISTRIBUTION IS UNLIMITED.

HEADQUARTERS, DEPARTMENT OF THE ARMY

18 SEPTEMBER 1989

CHANGE  
NO. 2

HEADQUARTERS  
DEPARTMENT OF THE ARMY  
WASHINGTON, D.C., 30 SEPTEMBER 1995

Operator's, Unit, Direct Support and General Support Maintenance Manual

SHELTER, ELECTRICAL EQUIPMENT  
S-280C/G (Unshielded) NSN 5411-01-092-0892  
S-280C/G (Shielded) NSN 5411-01-304-3069

DISTRIBUTION STATEMENT A Approval for public release; distribution is unlimited

TM 10-5411-207-14, 18 SEPTEMBER 1989, is changed as follows:

1. Title is changed as shown above.
2. Remove and insert pages as indicated below. New or changed text material is indicated by a vertical bar in the margin. An illustration change is indicated by a miniature pointing hand.

**Remove pages**

i thru iv

1-1 thru 1-4

2-3 and 2-4

3-1 and 3-2

3-31 and 3-32

3-35 thru 3-42

4-1 and 4-2

5-1/(5-2 blank)

A-1/(A-2 Blank)

B-3 and B-4

C-1 and C-2

D-1 and D-2

INDEX-3 and INDEX-4

**Insert pages**

i thru iv

1-1 thru 1-4

2-3 and 2-4

3-1 and 3-2

3-6.1/(3-6.2 blank)

3-31 and 3-32

3-35 thru 3-42

4-1 and 4-2

5-1/(5-2 blank)

A-1/(A-2 Blank)

B-3 and B-4

C-1 and C-2

D-1 and D-2

INDEX-3 and INDEX-4

3. Retain this sheet in front of manual for reference purposes.

By Order of the Secretary of the Army:

Official:

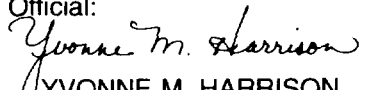
  
YVONNE M. HARRISON  
*Administrative Assistant to the  
Secretary of the Army*

00991

DENNIS J. REIMER  
*General, United States Army  
Chief of Staff*

**DISTRIBUTION:**

To be distributed in accordance with DA Form 12-25-E, block no. 2745, requirements for  
TM 10-5411-207-14.

CHANGE  
NO. 1

HEADQUARTERS  
DEPARTMENT OF THE ARMY  
WASHINGTON, D.C., 29 OCTOBER 1993

Operator's, Unit,  
Direct Support and General Support  
Maintenance Manual  
for  
SHELTER, ELECTRICAL EQUIPMENT S-280C/G  
(NSN 5411-01-092-0892)

DISTRIBUTION STATEMENT A: Approved for public release; distribution is unlimited.

TM 10-5411-207-14, 18 September 1989, is changed as follows:

1. Remove and insert pages as indicated below. New or changed text material is indicated by a vertical bar in the margin. An illustration change is indicated by a miniature pointing hand.

Remove pages

i through iv  
1-1 through 1-4  
3-5 and 3-6  
3-13 through 3-16  
3-21 through 3-44  
3-61 and 3-62  
4-3 and 4-4  
4-7 through 4-16  
B-5/(B-6 blank)  
C-3/(C-4 blank)  
D-1 and D-2

Insert pages

i through iv  
1-1 through 1-4  
3-5 and 3-6  
3-13 through 3-16  
3-21 through 3-44  
3-61 and 3-62  
4-3 and 4-4  
4-7 through 4-16  
B-5/(B-6 blank)  
C-3/(C-4 blank)  
D-1 and D-2

2. Retain this sheet in front of manual for reference purposes.

By Order of the Secretary of the Army:

Official

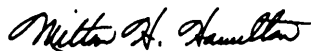

**MILTON H. HAMILTON**

*Administrative Assistant to the  
Secretary of the Army*

05766

**GORDON R. SULLIVAN**  
*General United States Army  
Chief of Staff*

DISTRIBUTION:

To be distributed in accordance with DA Form 12-25-E, block no. 2745, requirements for TM 10-5411-207-14.

**WARNING**

Drilling creates metal chips which may enter eyes and cause serious injury. Eye protection is required.

**WARNING**

Adhesives and solvents are flammable and toxic. Keep away from heat and open flames. Use in a well-ventilated area. Avoid skin and eye contact and breathing of vapors. Use protective goggles and gloves. Use in accordance with manufacturer's instructions. For Artificial Respiration, refer to FM21-11.

**WARNING**

Gloves are to be worn when mixing and applying adhesive material due to possible skin irritation caused by adhesive coming into contact with the body skin surface. The Versamid material is extremely sensitive to moisture absorption. Therefore, make sure Versamid 140 container has lid firmly replaced after material has been removed from shipping or storage container. Both the Epic R1003 and the Versamid 140 (Items 4 and 5, Appendix D) materials have a shelf life of one year.

**WARNING**

All personnel must remain clear of truck while shelter is being lowered into place.

TECHNICAL MANUAL  
NO. 10-5411-207-14

HEADQUARTERS  
DEPARTMENT OF THE ARMY  
WASHINGTON, D.C., 18 September 1989

Operator's, Unit, Direct Support,  
and General Support Maintenance Manual

**SHELTER, ELECTRICAL EQUIPMENT**  
S-280C/G NSN 5411-01-092-0892 (Unshielded)  
S-280C/G NSN 5411-01-304-3069 (Shielded)

**REPORTING ERRORS AND RECOMMENDING IMPROVEMENTS**

You can help improve this manual. If you find any mistakes, or if you know of a way to improve these procedures, please let us know. Mail your letter or DA Form 2028 (Recommended Changes to Publications and Blank Forms), or DA Form 2028-2 located in the back of this manual directly to: Commander, US Army Aviation and Troop Command, ATTN: AMSAT-I-MP, 4300 Goodfellow Blvd., St. Louis, MO 63120-1798. You may also submit your recommended changes by E-mail directly to <daf2028@st-louis-emh7.army.mil>. A reply will be furnished directly to you.

The following format shall be used for electronic 2028s. The subject line must be exactly the same and all fields must be included; however only the following fields are mandatory: 1, 3, 4, 5, 6, 7, 8, 9, 10, 13, 15, 16, 17, and 27.

From: "Whomever" <whomever@avma27.army.mil>  
To: mpmt@avma27.army.mil

Subject: DA Form 2028

- |  |   |
|--|---|
| 1. <b>From:</b> Joe Smith              | 15. <b>Submitter LName:</b> Smith               |
| 2. <b>Unit:</b> home                   | 16. <b>Submitter Phone:</b> 123-123-1234        |
| 3. <b>Address:</b> 4300 Park           | 17. <b>Problem:</b> 1                           |
| 4. <b>City:</b> Hometown               | 18. <b>Page:</b> 2                              |
| 5. <b>St:</b> MO                       | 19. <b>Paragraph:</b> 3                         |
| 6. <b>Zip:</b> 7777                    | 20. <b>Line:</b> 4                              |
| 7. <b>Date Sent:</b> 19-OCT-93         | 21. <b>NSN:</b> 5                               |
| 8. <b>Pub no:</b> 55-2840-229-23       | 22. <b>Reference:</b> 6                         |
| 9. <b>Pub Title:</b> TM                | 23. <b>Figure:</b> 7                            |
| 10. <b>Publication Date:</b> 04-JUL-85 | 24. <b>Table:</b> 8                             |
| 11. <b>Change Number:</b> 7            | 25. <b>Item:</b> 9                              |
| 12. <b>Submitter Rank:</b> MSG         | 26. <b>Total:</b> 123                           |
| 13. <b>Submitter FName:</b> Joe        | 27. <b>Text:</b>                                |
| 14. <b>Submitter MName:</b> T          | This is the text for the problem below line 27. |

**TABLE OF CONTENTS**

		PAGE
<b>CHAPTER 1</b>	<b>INTRODUCTION</b> .....	1-1
Section I	<b>General Information</b> .....	1-1
Section II	<b>Equipment Description and Data</b> .....	1-2
<b>CHAPTER 2</b>	<b>OPERATING INSTRUCTIONS</b> .....	2-1
Section I	<b>Operator Preventive Maintenance Checks and Services (PMCS)</b> .....	2-1
Section II	<b>Operation Under Usual Conditions</b> .....	2-4
section III	<b>Operation Under Unusual Conditions</b> .....	2-4
<b>CHAPTER 3</b>	<b>UNIT MAINTENANCE INSTRUCTIONS</b> .....	3-1
Section I	<b>Lubrication</b> .....	3-1
Section II	<b>Repair Parts, Special Tools, TMDE, and Support Equipment</b> .....	3-1
section III	<b>Service Upon Receipt</b> .....	3-1
Section IV	<b>Troubleshooting</b> .....	3-5
Section V	<b>Maintenance Instructions</b> .....	3-7
Section VI	<b>Preparation for Shipment and Storage</b> .....	3-61
<b>CHAPTER 4</b>	<b>DIRECT SUPPORT MAINTENANCE INSTRUCTIONS</b> .....	4-1
Section I	<b>Repair Parts, Special Tools, TMDE, and Support Equipment</b> .....	4-1
Section II	<b>Troubleshooting</b> .....	4-1
section III	<b>Maintenance Instructions</b> .....	4-2
<b>CHAPTER 5</b>	<b>GENERAL SUPPORT MAINTENANCE INSTRUCTIONS</b> .....	5-1
Section I	<b>Repair Parts, Special Tools, TMDE, and Support Equipment</b> .....	5-1
Section II	<b>Maintenance Instructions</b> .....	5-1
<b>APPENDIX A</b>	<b>REFERENCES</b> .....	A-1
<b>APPENDIX B</b>	<b>MAINTENANCE ALLOCATION CHART</b> .....	B-1
<b>APPENDIX C</b>	<b>COMPONENTS OF END ITEM AND BASIC ISSUE ITEMS LISTS</b> .....	C-1
<b>APPENDIX D</b>	<b>EXPENDABLE/DURABLE SUPPLIES AND MATERIALS LIST</b> .....	D-1
<b>INDEX</b> .....		Index-1

**LIST OF ILLUSTRATIONS**

Figure Number	Title	Page
1-1	Major Shelter Components .....	1-3
1-2	Shelter Marking .....	1-4
1-3	Instruction and Warning Plates .....	1-5
3-1	Lifting and Loading Shelter .....	3-3
3-2	Securing Shelter on Truck .....	3-5
3-3	Rivet Types .....	3-8
3-4	Installing Blind Rivets .....	3-10
3-5	Removing Blind Rivets .....	3-11
3-6	Rivnuts (Threaded Inserts) .....	3-12
3-7	Installing Rivnuts .....	3-13
3-8	Removing Rivnuts .....	3-15
3-9	Repair of Turning Rivnut .....	3-16
3-10	Overall Shelter Assembly Inspection .....	3-20
3-11	Drip Molding Removal/Installation .....	3-21
3-12	Hand Hold Replacement .....	3-23
3-13	T-Latch Replacement .....	3-24
3-14	Drain Plug Replacement .....	3-26
3-15	Data Plate Replacement .....	3-28
3-16	Hinge Assembly Replacement .....	3-30
3-17	Typical Locations for Door Gasket Testing .....	3-33
3-18	Weather Gasket and Seal Pressure Adjustment .....	3-33
3-19	Door Assembly Replacement .....	3-34
3-20	Door Assembly Maintenance .....	3-37
3-21	Typical Locations for Emergency Exit Panel Gasket Testing .....	3-39
3-22	Emergency Exit Panel Assembly and RFI/EMI Filter Replacement ..	3-40
3-23	Door Latch Replacement .....	3-46
3-24	Keeper Assembly Removal .....	3-48
3-25	Door Brace Assembly Removal .....	3-50
3-26	Door Brace Assembly Maintenance .....	3-51
3-27	Recessed Step Pan Assembly Replacement .....	3-53
3-28	Towing Eye Assembly Replacement .....	3-54
3-29	Lifting and Tiedown Eye Assembly Replacement .....	3-55
3-30	Skid Assembly Repair .....	3-57
3-31	Hold Down Assembly Repair .....	3-60
3-32	Truck Tiedown .....	3-61
3-33	Rail Tiedown .....	3-62
4-1	Skin Panel Delamination Repair .....	4-4
4-2	Shelter Wall Repair of Small Dent .....	4-8
4-3	Shelter Wall Repair of Large Dent .....	4-10
4-4	Shelter Wall Repair of Small Skin Puncture .....	4-12
4-5	Shelter Wall Repair of Large Skin Puncture or Cut .....	4-15



**LIST OF TABLES**

<b>Table Number</b>	<b>Title</b>	<b>Page</b>
2-1	Operator Preventive Maintenance Checks and Services . . . . .	2-2
3-1	Troubleshooting.....	3-6
3-2	Blind Rivets.....	3-9
3-3	Rivnuts . . . . .	3-13
3-4	Maximum Torque Requirement for Rivnut Screws . . . . .	3-16
4-1	Troubleshooting . . . . .	4-2

**HOW TO USE THIS MANUAL**

This manual was prepared to help keep your S-280C/G Unshielded and S-280C/G Shielded shelters in good operating condition. The front cover index is provided for quick reference to important information. There is also an alphabetical index at the back of the manual to locate specific items of information.

Warning pages are located at the front of this manual. You should read and completely understand all of the warnings before performing any maintenance on the equipment.

Paragraphs in this manual are numbered by chapter and order of appearance within a chapter. A subject index appears at the beginning of each chapter listing sections that are included in that chapter. A more specific subject index is located at the beginning of each section to help you find the exact paragraph you are looking for.

CHAPTER 1

INTRODUCTION

Subject	Section	Page
General Information . . . . .	I	1-1
Equipment Description and Data . . . . .	II	1-2

Section I. GENERAL INFORMATION

Subject	Para	Page
Scope . . . . .	1-1	1-1
Maintenance Forms and Records . . . . .	1-2	1-1
Reporting Equipment Improvement Recommendations . . . . .	1-3	1-1
Destruction of Army Materiel to Prevent Enemy Use . . . . .	1-4	1-1
Preparation for Shipment and Storage . . . . .	1-5	1-1
Warranty Information . . . . .	1-6	1-2
List of Abbreviations . . . . .	1-7	1-2

1-1. Scope.

- a. Type of Manual. This technical manual includes operator, unit, direct support, and general support maintenance procedures for the S-280C/G Unshielded and S-280C/G Shielded shelters. Additional maintenance data relevant to a specifically configured shelter can be found in the applicable end item technical manual.
- b. Equipment Name and Model Number. This technical manual describes Electrical Equipment Shelter S-280C/G Unshielded and S-280C/G Shielded. The S-280C/G Shielded shelter is equipped with radio frequency/electromagnetic interference shielding.
- c. Purpose of Equipment. The S-280C/G Unshielded and S-280C/G Shielded are lightweight transportable shelters designed to house a wide variety of military systems and components.

1-2. **Maintenance Forms and Records.** Department of the Army forms and procedures used for equipment maintenance will be those prescribed by DA Pam 738-750, The Army Maintenance Management System (TAMMS). Refer to the latest issue of DA Pam 25-30 (Consolidated Index of Army Publications and Blank Forms) to determine if there are new editions, changes or additional publications pertaining to the equipment.

1-3. **Reporting Equipment Improvement Recommendations.** If your shelter needs improvement, let us know. Send us an EIR. You, the user, are the only one who can tell us what you don't like about your equipment. Let us know why you don't like the design or performance. Put it on an SF 368 (Quality Deficiency Report). Mail it to: Commander, US Army Aviation and Troop Command, ATTN: AMSAT-I-MDO, 4300 Goodfellow Blvd., St. Louis, MO 63120-1798. We'll send you a reply.

1-4. **Destruction of Army Materiel to Prevent Enemy Use.** Destruction of Army equipment to prevent enemy use shall be in accordance with TM 750-244-3.

**1-5. Preparation for Shipment and Storage.** Refer to paragraphs 3-29 for shipment and storage preparation data.

**1-6. Warranty Information.** The S-280C/G Unshielded and S-280C/G Shielded shelters are warranted by Gichner Shelter Systems for 12 months or by Ramim Engineering Works, Ltd. for 24 months. Warranty starts on the date found on DA Form 2408-9 (Equipment Control Record) in the logbook. Report all defects in material or workmanship to your supervisor who will take appropriate action. Refer to Warranty Technical Bulletin TB 10-5411-207-14 (Gichner) or TB 10-5411-207-24-1 (Ramim).

**1-7. List of Abbreviations.**

EMI	Electromagnetic Interference
RFI	Radio Frequency Interference
RTV	Room Temperature Vulcanizing
TMDE	Test, Measurement, and Diagnostic Equipment

**Section II. EQUIPMENT DESCRIPTION AND DATA**

Subject	Para	Page
Equipment Characteristics, Capabilities, and Features .....	1-8	1-2
Location and Description of Major Components .....	1-9	1-2
Equipment Data .....	1-10	1-3
Shelter Marking .....	1-11	1-3
Instruction and Warning Plates .....	1-12	1-4
Safety, Care, and Handling .....	1-13	1-5

**1-8. Equipment Characteristics, Capabilities, and Features.** The S-280C/G Unshielded and S-280C/G Shielded shelters are lightweight, relocatable shelters used to transport and house various types of equipment. The foam and beam shelter construction consists of aluminum face sheets enclosing a polyurethane foam composition core. The shelter is designed for outdoor use in all weather conditions. The shielded shelters are equipped with radio frequency/electromagnetic (RFI/EMI) shielding to protect the electronic equipment contained inside. The shield is a continuous metallic surface which includes the shelter panel outer face sheets and conductive materials which maintain continuity around joints, door openings, and other possible sources of radiation leak. Shielded shelters also have a RFI/EMI filter inside the emergency exit panel. Shielded shelters can be identified by the metallic door gasket which mates with another conductive surface on the door jamb.

**1-9. Location and Description of Major Components.** (Figure 1-1)

ITEM	DESCRIPTION
1. Door assembly	Provides personnel access to interior of shelter.
2. Emergency exit panel assembly	Provides emergency personnel exit and allows fresh air to enter shelter
3. Lifting and tiedown eye assembly	Provides hookup point for sling assembly when lifting shelter and when securing shelter onto truck.

**1-2 Change 2**

- |    |                             |  |
|----|-----------------------------|--|
| 4. | Towing eye assembly         | Provides hookup point for cable assembly when towing shelter and for guide rope when guiding sling-lifted shelter into position. |
| 5. | Pan assembly recessed steps | Allows access to roof  |
| 6. | Skid assemblies             | Permit a fully equipped shelter to be towed for limited distance over rough terrain. They also provide forklift access           |

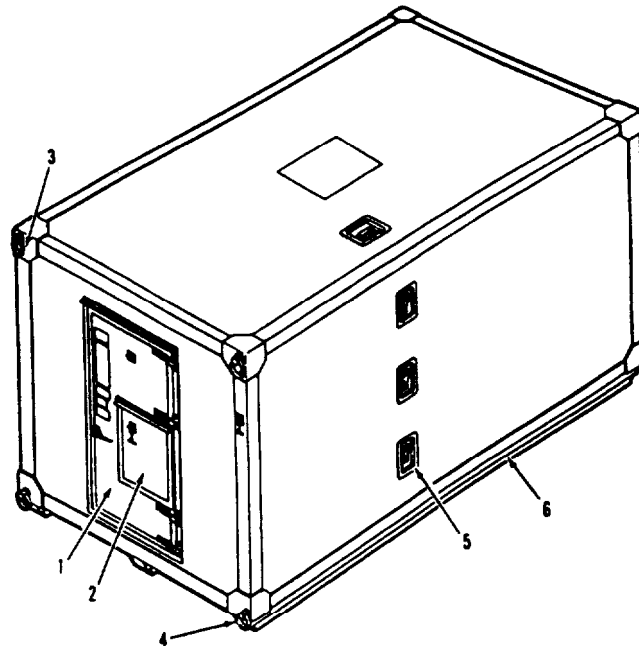

Figure 1-1. Major Shelter Components.

1-10. **Equipment Data.**

Height	86.375 in (219.4 cm)
Width	87 in (220.9 cm)
Length	147 in (373.38 cm)
Gross weight	(Unshielded) 1,400 lbs (636.4 kg) (Shielded) 1,400 lbs (640.9 kg)
Payload	5,000 lbs
Cubage	640 ft <sup>3</sup> (59.4 m <sup>3</sup> )
Load on skids	0.96 psi (4.69 kPa)

1-11. **Shelter marking.** Shelter markings are shown in Figure 1-2. Lettering is stenciled or silkscreened in accordance with MIL-M-13231 GR II. The color used is black, MIL-C-46168.

**NOTE**

For camouflage shelters, lettering is green 383 on black background; and lettering is black on green and brown backgrounds (MIL-C-46168).

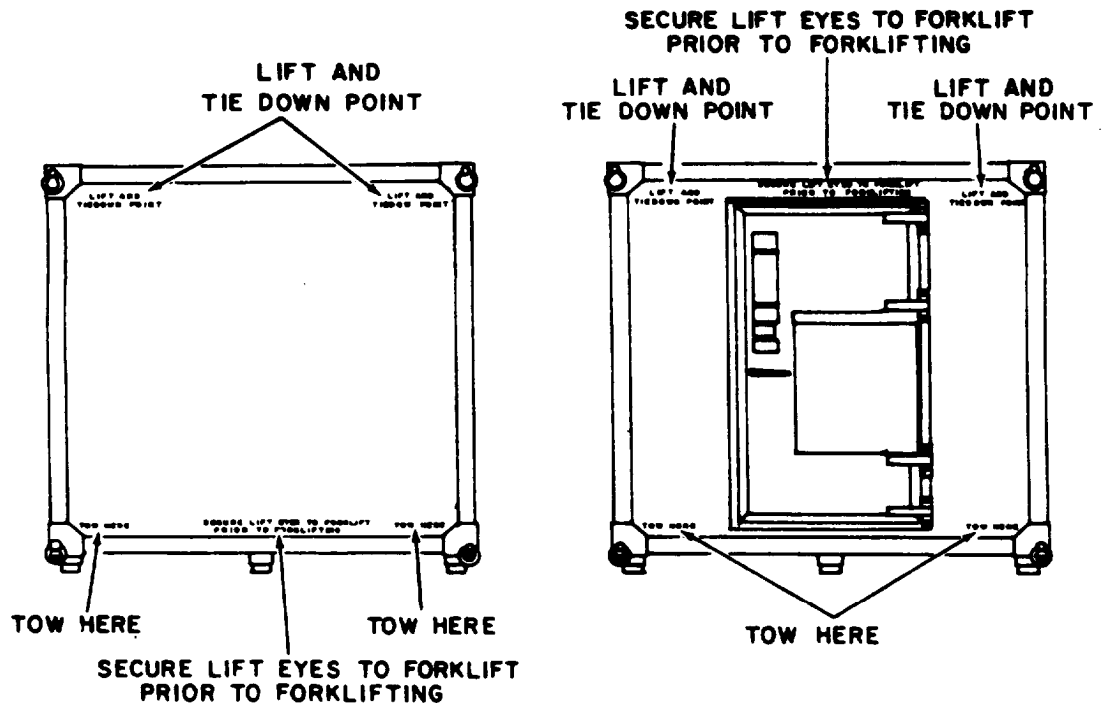

Figure 1-2. Shelter Marking.

1-12. **Instruction and Warning Plates** (Figure 1-3)

CONTENT

- |    |                   |   |
|----|-------------------|---|
| 1. | Instruction Plate | The surfaces of this shelter have been painted with CARC<br>For touch-up<br>Exterior - Use only lusterless green 383, brown 383 or black polyurethane IAW ML-C-46168<br>Interior - Use only epoxy polyamide IAW MIL-C-22750 |
| 2. | Instruction Plate | Secondary exit. Remove 4 hand knobs. Lift out exit panel.   |
| 3. | Instruction Plate | Unlatch vent cover during airlift.<br>Keep vent cover open when shelter is occupied.<br>Remove drain plug during air and rail transport.  |
| 4. | Instruction Plate | Push catch to release door stop brace.  |

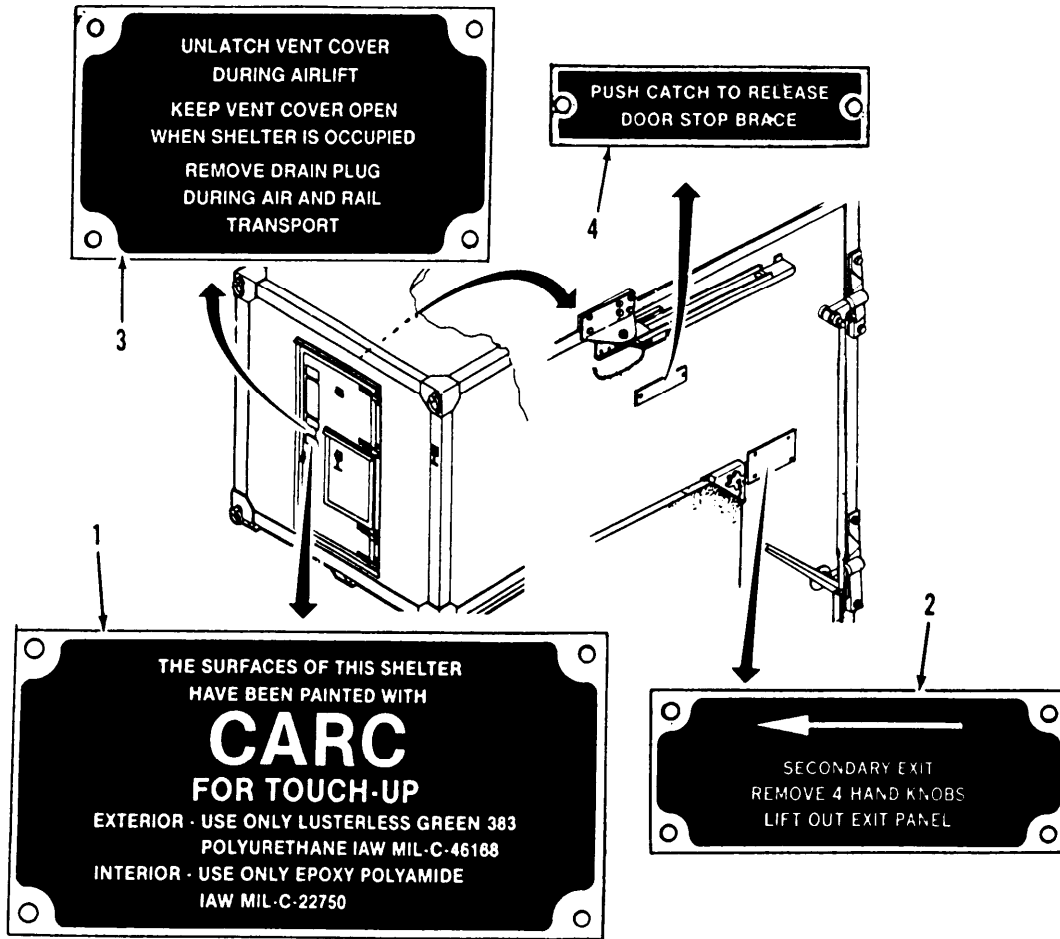

Figure 1-3. Instruction and Warning Plates.

**1-13. Safety, Care, and Handling.** Warnings, cautions, and notes designed to protect personnel and equipment when handling the shelter are located throughout this manual. Know the warnings before attempting to perform any maintenance on the shelter, and observe all warnings, cautions, and notes as you come upon them in the text.

## CHAPTER 2

### OPERATING INSTRUCTIONS

Subject	Section	Page
Operator Preventive Maintenance Checks and Services (PMCS) . . . . .	I	2-1
Operation Under Usual Conditions . . . . .	II	2-4
Operation Under Unusual Conditions . . . . .	III	2-4

#### Section I. OPERATOR PREVENTIVE MAINTENANCE CHECKS AND SERVICES (PMCS)

Subject	Para	Page
General . . . . .	2-1	2-1
Purpose of PMCS Table . . . . .	2-2	2-1
Explanation of Columns . . . . .	2-3	2-1

**2-1. General.** To be sure the shelter is always ready for use, it must be inspected at specific intervals so defects can be located and corrected before they result in serious damage or failure.

*a. Before You Operate.* Always keep in mind the CAUTIONS and WARNINGS. Perform your before (B) PMCS.

*b. While You Operate.* Always keep in mind the CAUTIONS and WARNINGS. Perform your during (D) PMCS.

*c. After You Operate.* Be sure to perform your after (A) PMCS.

*d. Weekly.* Perform your weekly (W) PMCS.

*e. Once Each Month.* Perform your monthly (M) PMCS.

*f. If Your Equipment Fails to Operate.* If your equipment does not perform as required, notify higher level of maintenance. Report any malfunctions or failures on the proper DA Form 2404 or refer to DA Pam 738-750.

**2-2. Purpose of PMCS Table.** The Preventive Maintenance Checks and Services table lists the inspections required to keep the equipment in good operating condition.

**2-3. Explanation of Columns.**

*a. Item Number.* The item number is to be used as a source number for the TM number column on DA Form 2404, Equipment Inspection and Maintenance Worksheet, when recording PMCS results.

*b. Item to Be Inspected.* This column list the components that require inspection.

*c. Procedures.* This column lists the faults to check for and procedures to follow.

**2-3. Explanation of Columns (cont).**

d. Equipment is Not Ready/Available If This column tells you when and why your equipment cannot be used.

**NOTE**

Perform your “weekly checks” in addition to the “before checks” if you are the assigned operator and have not operated the equipment since the last weekly check was performed, or if you are operating the equipment for the first time.

*Table 2-1. Operator Preventive Maintenance Checks and Services.*

**NOTE**

Within designated interval, these checks are to be performed in the order listed.

Item	Interval					Item to be Inspected	Procedures Check for and have repaired or adjusted as necessary	Item is Not Ready/ Available if:
	B	D	A	w	M			
1	Ž			Ž		Door Handle	Make sure handle on door operates smoothly without binding or jamming.	Door cannot be opened or cannot be closed securely.
2	Ž			Ž		Emergency Exit Panel Assembly	a. Make sure emergency exit panel assembly can be removed.  b. Make sure weather gasket is in good condition.  c. Make sure cover assembly can be held in the open position.	a. Emergency exit panel assembly cannot be removed.
3	Ž			Ž		Door Brace Assembly	Make sure door brace assembly moves smoothly to open position and catch holds brackets in place. Check for loose or missing hardware.	
4	Ž			Ž		Door Assembly	a. Make sure door opens and closes smoothly without binding. Check for rust, loose or missing hardware. Lubricate hinges.	a. Door cannot be opened or cannot be closed securely.



Table 2-1. Operator Maintenance Checks and Services (cont).

Item	Interval					Item to be Inspected	Procedures Check for and have repaired or adjusted as necessary	Item is Not Ready/ Available if:
	B	D	A	W	M			
4						Door Assembly (cont)	b. Make sure drip molding is intact. c. Make sure air filters and louvers are not blocked. d. Check door surfaces for punctures e. Make sure weather gaskets are in good condition. f. (Shielded) Make sure EM gaskets are complete and intact. g. (Shielded) Make sure RFI filter is in place and undamaged.	c. Air filters or louvers are blocked.  f. Gasket is not intact. g. Filter is not intact.
5	•					Lifting and Towing Bracket assemblies	a. Inspect for excessive wear. b. Inspect for rust, loose or missing hardware. c. Make sure rings and pins rotate freely	
6						Roof Access Steps	a. Make sure steps stay in up or down position as required. b. Check for loose or missing hardware	
7						Roof Handle	Make sure handle is securely mounted to roof	
8		•				Drain Plug	Make sure drain plug is in place	
9	•					Wall, Floor and Ceiling Panels	Inspect for punctures and delamination	Punctures are present
10	•					Skids	Make sure skids are securely mounted to shelter and are undamaged.	

**Section II. OPERATION UNDER USUAL CONDITIONS**

Subject	Para	Page
Assembly and Preparation for Use . . . . .	2-4	2-4
Initial Adjustments . . . . .	2-5	2-4
Operating Procedure	2-6	2-4
Preparation for Movement . . . . .	2-7	2-4

2-4. **Assembly and Preparation for Use.** There are no assembly or preparation procedures that must be performed before using the basic shelter. For all assembly and preparation procedures applicable to a specifically configured shelter, refer to the end item technical manual.

2-5. **Initial Adjustments.** The shelter itself requires no adjusting. However, the operator must make certain the shelter is positioned so the door can be fully opened and closed and that any external equipment required for operation of the shelter-contained equipment can be properly installed. Refer to the end item technical manual for any adjustment procedures applicable to the configured shelter.

2-6. **Operating Procedure.** There are no operating procedures applicable to the basic shelter. Refer to the end item technical manual for operating procedures applicable to the specifically configured shelter.

2-7. **Preparation for Movement.** Before moving any shelter, make sure the door is closed and padlocked. If the shelter is being moved by truck, make sure the shelter is properly tied down and blocked to prevent movement. Refer to paragraph 3-5 for instructions for securing the shelter on a truck. If the shelter must be loaded onto a truck for movement, refer to paragraph 3-5 for lifting and loading instructions. Refer to the end item technical manual for additional preparation instructions applicable to a specifically configured shelter.

**Section III. OPERATION UNDER UNUSUAL CONDITIONS**

Subject	Para	Page
Operation in Unusual Weather . . . . .	2-8	2-4
Emergency Procedures . . . . .	2-9	2-4

2-8. **Operation in Unusual Weather.** The S-280C/G Unshielded and S-280C/G Shielded shelters are designed for use in all weather. However, shelters located at sites subject to salt air deterioration, or areas subject to wind-driven sand or coral dust shall be inspected by site personnel at least once every week to assure timely determination of maintenance and repair needs. Additional requirements for operation in unusual weather can be found in the end item technical manual.

2-9. **Emergency Procedures.** Any damage to the shelter walls or ceiling must be patched immediately to prevent possible water intrusion. In an emergency, any kind of tape or water-resistant materials may be used to cover a puncture or a large hole. Temporary patches must be replaced with permanent patches as soon as possible.

CHAPTER 3

UNIT MAINTENANCE INSTRUCTIONS

Subject	Section	Page
Lubrication . . . . .	I	3-1
Repair Parts, Special Tools, TMDE, and Support Equipment . . . . .	II	3-1
Service Upon Receipt . . . . .	III	3-1
Troubleshooting . . . . .	IV	3-5
Maintenance Instructions . . . . .	V	3-7
Preparation for Shipment and Storage . . . . .	VI	3-61

Section I. LUBRICATION

3-1. **Lubrication Instructions.** Lubricate door hinges, latches and locking mechanisms, door brace assemblies, roof access steps, and lifting and towing bracket assemblies to prevent rust and corrosion. Check these parts frequently to be sure they are adequately lubricated. Lubricate with Solid Film Lubricant, MIL-L-23398 (Item 22, Appendix D).

Section II. REPAIR PARTS, SPECIAL TOOLS, TMDE, AND SUPPORT EQUIPMENT

Subject	Para	Page
Common Tools . . . . .	3-2	3-1
Special Tools, TMDE, and Support Equipment . . . . .	3-3	3-1
Repair Parts . . . . .	3-4	3-1

3-2. **Common Tools.** A complete list of common tools and tool kits is given in Section III of Appendix B, Maintenance Allocation Chart.

3-3. **Special Tools, TMDE, and Support Equipment.** All special tools, TMDE, and support equipment are listed in Section III of Appendix B, Maintenance Allocation Chart, and in the Repair Parts and Special Tools List manual, TM 10-5411-207-24P, S-280C/G Shielded and S-280C/G Unshielded Electrical Equipment Shelters.

3-4. **Repair Parts.** Repair parts for unit maintenance of the shelter are listed and illustrated in TM 10-5411-207-24P.

Section III. SERVICE UPON RECEIPT

Subject	Para	Page
Service Upon Receipt of Material . . . . .	3-5	3-1
Site Requirements . . . . .	3-6	3-4

3-5. **Service Upon Receipt of Material.** Inspect the shelter for damage incurred during shipment. If the shelter has been damaged, report the damage on SF 361 Transportation Discrepancy Report (TDR). If the drain plug has been loosened for shipment, tighten it. If the shelter is crated or pallet-mounted, refer to the end item technical manual for unpacking instructions. If it is necessary for the shelter to be loaded onto a truck or transferred from one truck to another, lift, load, and secure the shelter as follows:

3-5. Service Upon Receipt of Materiel (cont).

**CAUTION**

If shelter panel is punctured during loading or securing, repair puncture as soon as possible to prevent moisture from seeping into panels.

a. Lifting Shelter. (Figure 3-1)

- (1) Attach sling assembly to all four lifting eyes on shelter so that turnbuckle ends of cables are next to lifting rings. Be sure to use correct sling assembly. (See Appendix C).
- (2) Place sling assembly on top of shelter.
- (3) Insert lifting hook of lifting device (crane or helicopter) into lifting ring.
- (4) Tie a 1/2-inch rope, at least 15 feet long, to each rear towing eye.

**CAUTION**

Do not jerk, bounce, or jar shelter when lifting. Avoid swinging shelter from side to side. Do not attempt to butt or push shelter into place with a forklift.

- (5) Slowly lift shelter with crane or helicopter.

b. Forklifting shelter.

**WARNING**

To prevent injury or death to personnel, make certain the personnel are clear of shelter when operating forklift.

**NOTE**

Both ends of shelter have stenciled forklifting instructions.

- (1) Place forks between outside skids at either end of shelter.
- (2) Attach securely lifting eyes of shelter to forklift truck before attempting to lift shelter.

**CAUTION**

To prevent toppling and damage to shelter, use extreme care in securing, lifting, carrying, and lowering shelter into its position.

- (3) Lift, carry, and place each shelter at its designated site position.
- (4) Lower the shelter into position, release lifting eyes from forklift and carefully retract the forks of the forklift from under the shelter by slowly backing up.

c. Loading Shelter onto Truck. (Figure 3-1)**WARNING**

To avoid injury to personnel and damage to shelter, only personnel actually engaged in loading operation should be permitted near truck, lifting device, and shelter. To eliminate confusion, all instructions must come from loading crew supervisor.

**NOTE**

The entrance door of the shelter must be at the rear of the truck, and the front end of the shelter must be placed flush against the front of the truck body.

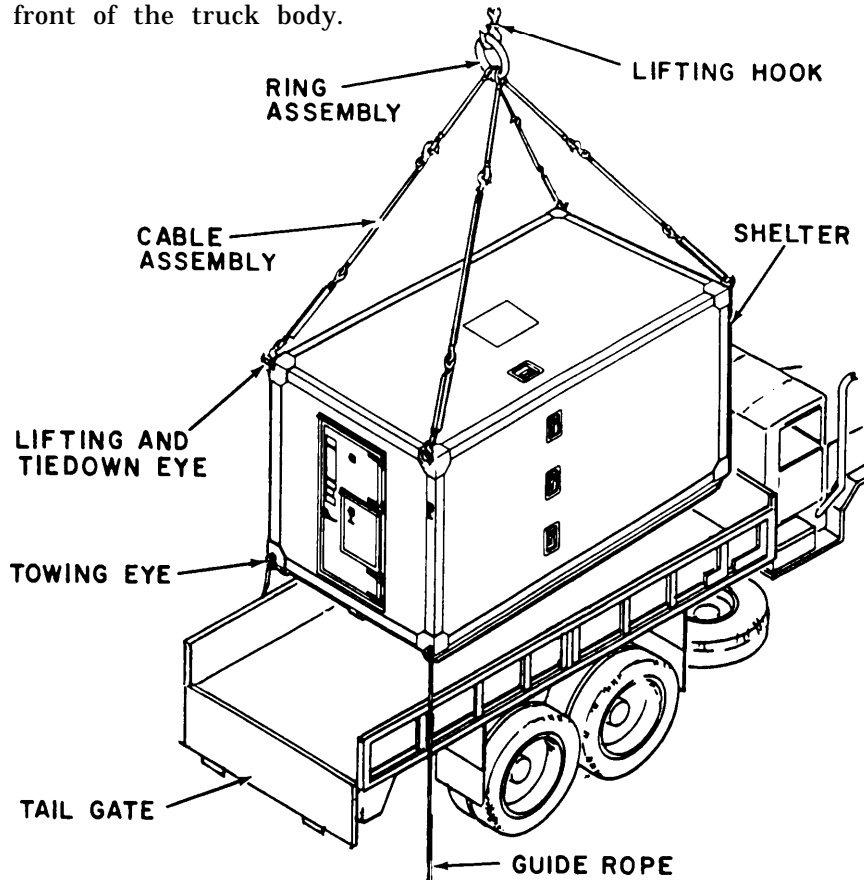

Figure 3-1. Lifting and Loading Shelter.

**NOTE**

Some procedures require the addition of dunnage to truck bed or the attachment of tiedown eyes to truck before loading shelter onto truck. Refer to technical manual for type of truck being used.

- (1) Lower truck tailgate (if applicable) and make sure all tools and equipment have been removed from truck bed.
- (2) Position one person at free end of each rope to guide shelter into place.

**3-5. Service Upon Receipt of Materiel (cont).**

- (3) Lift shelter to a position high enough to clear truck bed.
- (4) Back truck into position under shelter.

**WARNING**

All personnel must remain clear of truck while shelter is being lowered into place.

- (5) With one person at each rope, guide shelter into position so it is aligned above truck bed, and maintain that position while lowering shelter into place on truck bed.
- (6) Remove lifting ring from lifting hook and separate lifting ring from sling hooks. Remove sling hooks from lifting eyes and remove ropes from rear towing eyes.

*d. Securing Shelter on 2 1/2-Ton or 5-Ton Truck. (Figure 3-2)*

- (1) Install plate and eye bolt assemblies (part of sling assembly) on cargo bed side-rails of truck as shown in Figure 3-2.
- (2) Hook ends of four sling assemblies to tiedown eyes at each top corner of shelter, using hooks at furthest end of cables from turnbuckles.
- (3) Hook sling hooks at opposite end of cables to appropriate eye bolts on truck. Make sure sling hooks point away from shelter.

**CAUTION**

Do not overtighten turnbuckles. Overtightening may tear lifting and tiedown eyes from shelter or damage eye assembly or shelter.

- (4) Tighten all turnbuckles evenly by hand. Then, turn each turnbuckle an additional one-half turn with a bar or rod inserted in turnbuckle slot.
- (5) Insert appropriate size wooden blocks between shelter skids and sides of truck bed to prevent sideways movement strain on sling cables.
- (6) Insert appropriate size wooden blocks between shelter skids and cab wall to protect cab wall and shelter towing eyes,
- (7) Raise and secure truck tailgate.

**3-6. Site Requirements.** Prior to the delivery of the shelter at the destination point, consideration must be given to the size and weight of the shelter in order to have the necessary material, handling equipment, and space available. The shelter may be operated at unprepared locations. A level site is desired but is not absolutely necessary. Prior to unloading and deploying the shelter, the following site preparations must be accomplished.

- a. Determination of approximate position and orientation of the shelter on the selected site.

- b. Removal of any obstructions, debris, or large rocks that will interfere with the placing of the shelter.

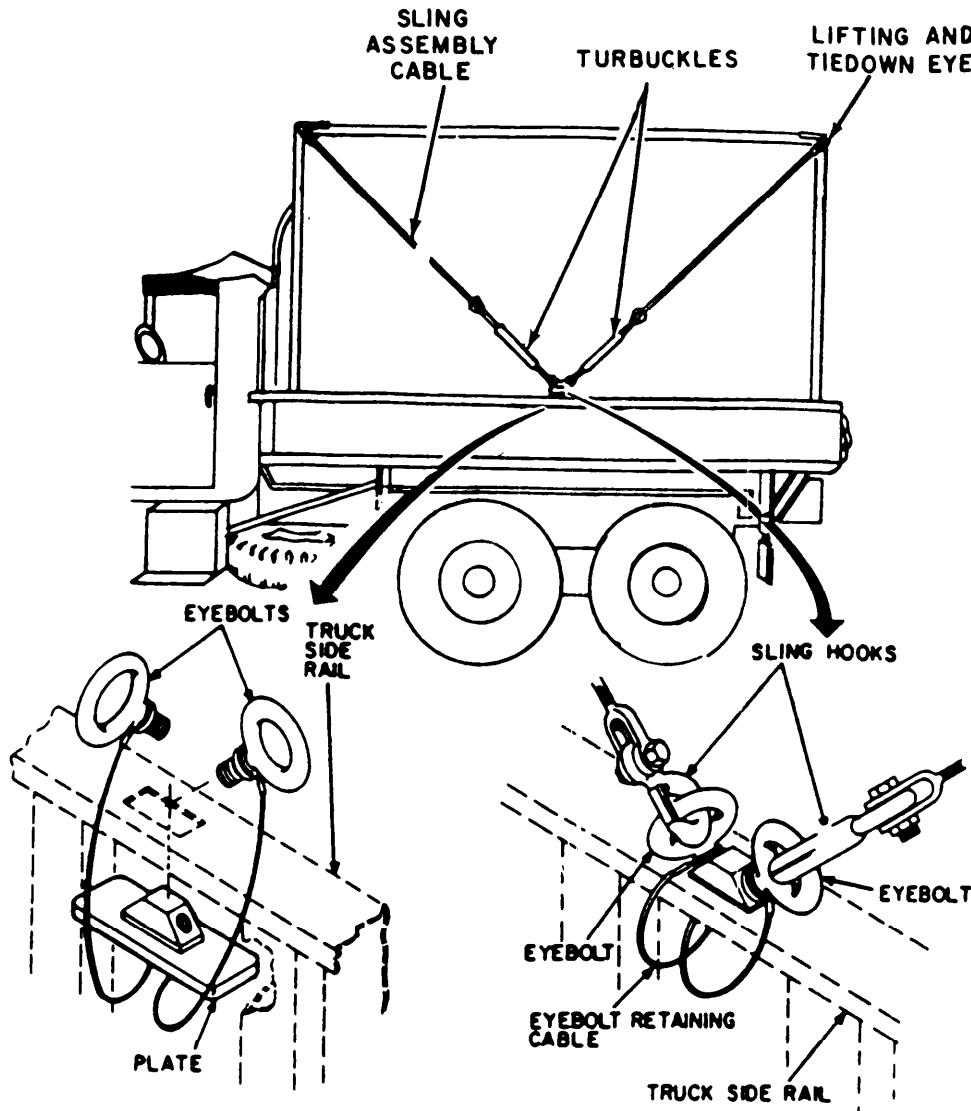

Figure 3-2. Securing Shelter on Truck.

### Section IV. TROUBLESHOOTING

**3-7. Troubleshooting.** This section contains troubleshooting information for malfunctions which may develop in the shelter. Fault isolation is limited to those components which may be repaired or replaced at the unit level. Table 3-1 lists the common malfunctions you may encounter during operation or maintenance of the shelter. Each malfunction is followed by a list of tests or inspections and corrective actions. These tests or inspections and corrective actions should be performed in the order listed. This manual cannot list all malfunctions that may occur. If you encounter a malfunction that is not listed or that cannot be corrected by the listed corrective actions, notify your supervisor.

Table 3-1. Troubleshooting.

---

**MALFUNCTION**

**TEST OR INSPECTION**

**CORRECTIVE ACTION**

---

1. DOOR DOES NOT OPEN OR CLOSE SMOOTHLY

Step 1. Inspect hinges for adequate lubrication.  
Lubricate as required (paragraph 3-1).

Step 2. Adjust or repair door as necessary (paragraph 3-18).

2. DOOR DOES NOT STAY OPEN

Step 1. Check to see if door brace catch is installed in lower brace bracket.  
Install catch in bracket (paragraph 3-22).

Step 2. Check to see if door brace catch is damaged.  
Install new door brace catch on lower brace bracket.

3. DOOR HANDLE IS JAMMED OR DOES NOT OPERATE SMOOTHLY

Step 1. Inspect components for adequate lubrication.  
Lubricate as required (paragraph 3-1).

Step 2. Inspect door handle and latching mechanism for missing or damage components.  
Repair or replace components as required (paragraph 3-20).

4. WATER IS GETTING INTO SHELTER

Step 1. Inspect shelter walls and ceiling for leaks.  
Patch any holes (paragraph 3-9.c).

Step 2. Check to see if roof access steps have pulled away from shelter wall.  
Apply sealer to gaps around step flange, or replace step (paragraph 3-23).

Step 3. Check condition of weather gaskets on door.  
Replace deteriorated gaskets (paragraph 3-18).

Step 4. Check condition of drip molding.  
Replace defective drip molding (paragraph 3-12).

---



*Table 3-1. Troubleshooting (cont).*

---

<b>MALFUNCTION</b>	<b>TEST OR INSPECTION</b>	<b>CORRECTIVE ACTION</b>
<hr/>		
5. (Shielded) THERE IS EVIDENCE OF RADIO FREQUENCY/ELECTROMAGNETIC INTERFERENCE		
	Step 1.	Inspect shelter walls, ceiling , and floor for holes. If repair is required, refer to direct support.
	Step 2.	Check to see that all exterior wall and ceiling patches are firmly mounted and bonded. If replacement of patches is required, refer to direct support.
	Step 3.	Check condition of RF1/EMI filter in door. Replace damaged or missing filter (paragraph 3-19).

---

**Section V. MAINTENANCE INSTRUCTIONS**

Subject	Para	Page
General . . . . .	3-8	3-7
General Repair Procedures . . . . .	3-9	3-8
Shelter Assembly . . . . .	3-10	3-17
Overall Shelter Assembly . . . . .	3-11	3-19
Drip Molding (Above Door) . . . . .	3-12	3-21
Hand Hold (Roof) . . . . .	3-13	3-22
T-Latch Assembly . . . . .	3-14	3-24
Drain Plug . . . . .	3-15	3-25
Plates . . . . .	3-16	3-27
Hinge Assembly . . . . .	3-17	3-29
Door Assembly . . . . .	3-18	3-31
Emergency Exit Panel Assembly . . . . .	3-19	3-38
Door Latch Assembly . . . . .	3-20	3-43
Keeper Assembly . . . . .	3-21	3-47
Door Brace Assembly . . . . .	3-22	3-49
Recessed Step Pan Assembly . . . . .	3-23	3-52
Towing Eye Assembly . . . . .	3-24	3-54
Lifting and Tiedown Eye Assembly . . . . .	3-25	3-55
Skid Assembly . . . . .	3-26	3-56
Hold Down Assembly . . . . .	3-27	3-59
Touch-Up Painting . . . . .	3-28	3-61

**3-8. General.** Since most shelters contain sensitive electronic equipment that cannot be easily removed, unit level maintenance and repair will Primarily involve shelter exteriors or easily accessible interior areas, unless floors, ceilings or walls have evidence of water intrusion which can jeopardize operation of the equipment. The shelter shall be returned to the depot for repair if any of the following conditions exist:

- a. Panel damage spans a structural member.
- b. Replacement of an entire wall, ceiling, or floor is required.
- c. Extensive equipment removal beyond the capability of the using unit is required.
- d. Welding is required,
- e. Damage to a structural member is severe enough to cause distortion of a wall, especially in edge or corner areas.
- f. Lift, tow, or tiedown fittings or corner castings are damaged severely enough to indicate possible damage to the underlying structural member.

3-8. General (cont).

NOTE

If nature of damage warrants, print a caution notice using 4-inch high letters on all outside walls of the shelter as follows:  
CAUTION: DAMAGED SHELTER. DO NOT SLING LIFT.

Coat threads of all screws and bolts with sealer before installing.  
Fill rivet and rivnut holes with sealer before using.

Unless otherwise noted, all procedures can be performed by one person using standard tools listed in Appendix B, Section III.

3-9. General Repair Procedures. The procedures described in this paragraph are general procedures that may be needed during repair or replacement of many of the shelter components. Wherever these general procedures apply, they are referenced at the appropriate point in the specific maintenance procedure paragraph.

a. Blind Rivet Installation and Removal. Blind rivets are used in locations where only one side of the area to be worked on is accessible. Blind pop rivets must be used in the shelter foam and beam panels, since the hammering required to install conventional rivets would damage the material. The types of rivets used in the shelter are shown in Figure 3-3 and described in Table 3-2. When installing floor patches, countersunk head rivets (styles K and T) are preferred, but dome head rivets (styles R and S) are an acceptable alternate. When installing interior wall patches, countersunk head rivets shall be used in any location in which dome head rivets will interfere with the proper installation of equipment. Closed end rivets (styles K and R) must be used for exterior repairs and floor repairs--to prevent moisture and dirt from entering panels.

NOTE

Open end rivets may be used only where moisture and dirt entrance will not affect the shelter.

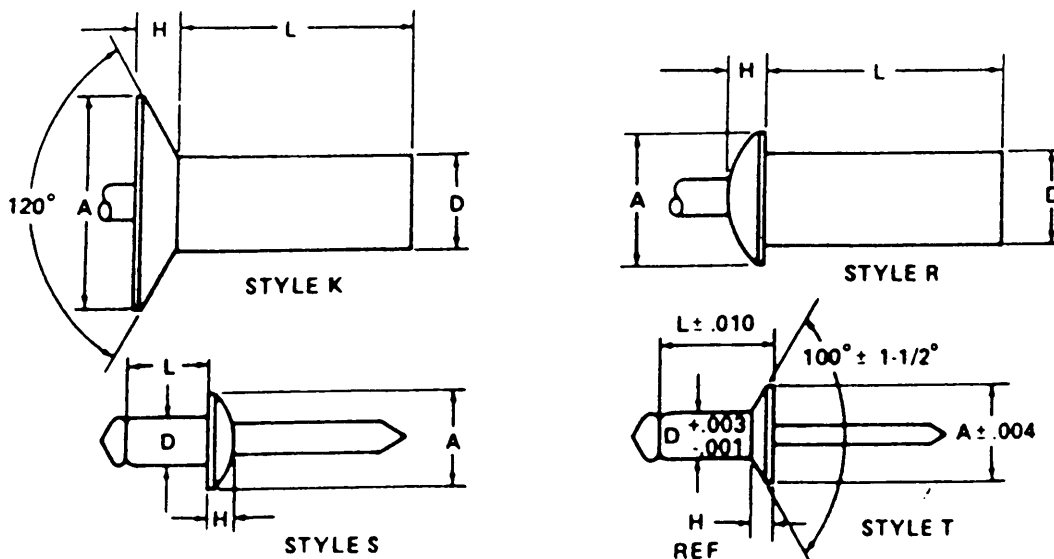

Figure 3-3. Rivet Types.

**3-9. General Repair Procedures (cont).**

Table 3-2. Blind Rivets.

Part No. 1/	Style	Dim A	Dim H	Dim D	Dim L
AD42H	R	0.236	0.051	1/8	0.361
AD43H	R	0.236	0.051	1/8	0.377
AD45H	R	0.236	0.051	1/8	0.502
AD62H	R	0.375	0.081	3/16	0.345
AD64H	R	0.375	0.081	3/16	0.470
AD68H	R	0.375	0.081	3/16	0.720
AD42S	R	0.236	0.051	1/8	0.361
MS20470AD6-8	R	0.375	0.080	3/16	0.375
NAS1398D4-3	R	0.250	0.067	0.156	0.326
NAS1398D4-4	R	0.250	0.067	0.156	0.388
NAS1398D6-3	R	0.375	0.080	0.187	0.350
NAS1398D6-5	R	0.375	0.080	0.187	0.475
NAS1398D6-8	R	0.375	0.080	0.187	0.662
NAS1399D4-4	R	0.225	0.042	0.125	0.385
NAS1399D6-6	R	0.353	0.070	0.187	0.537
NAS1739E4-3	R	0.286	0.047	0.173	0.375

1/ Part Number Code Explanations

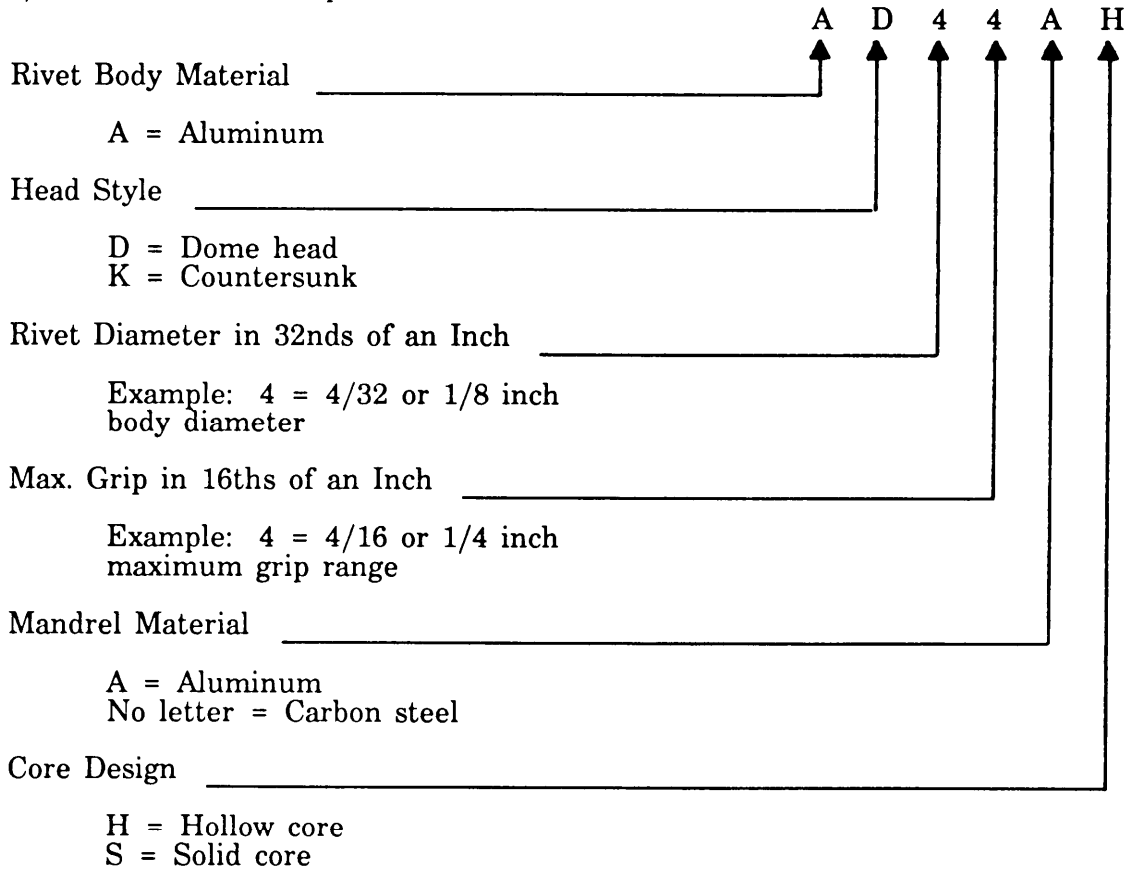

**3-9. General Repair Procedures (cont).**

(1) Installation. (Figure 3-4)

**NOTE**

When installing new rivet in same location as a rivet that has been removed, if diameter of hole in structure has been enlarged during removal of rivet, use next larger diameter rivet for replacement.

Clean rivets with solvent before installing.

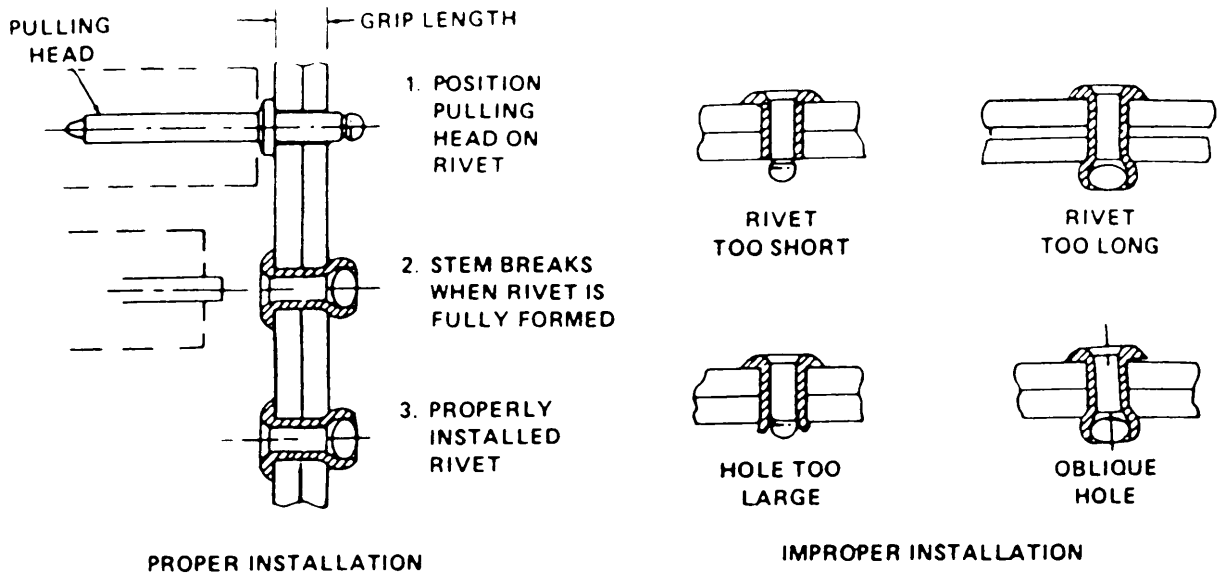

Figure 3-4. Installing Blind Rivets.

(a) Determine type, size and grip range of rivet to be used. Grip length equals combined thickness of materials being riveted together. Grip range of rivet must encompass grip length.

**WARNING**

Drilling creates metal chips which may enter eyes and cause serious injury. Eye protection is required.

**CAUTION**

Do not drill deeper than necessary to install rivet as you may drill through other side of panel.

**NOTE**

Drill hole size must match size of rivet being used.

Quantities of sheets may be drilled at the same time when held together with sheet fasteners.

**3-9. General Repair Procedures (cont).**

- (b) Drill hole in structure.
- (c) Remove all metal chips and remove burrs from drilled holes.
- (d) If flush head rivet is being installed, countersink hole using a 100-degree or 120-degree machine countersink.
- (e) Coat all rivet bodies with sealer (Item 26, Appendix D) before installing.
- (f) Insert rivet in hole. Make sure sheets are held tightly together before upsetting or pulling rivet.
- (g) Select proper pulling head for rivet being installed and install pulling head on rivet gun.
- (h) Insert stem of rivet into pulling head.
- (i) With pulling head parallel to axis of rivet, upset rivet. Exert firm pressure but do not bend or buckle metal sheets. Stem will break off below rivet head surface. No trimming should be required.
- (j) Make sure riveted parts are not loose, rivet does not rotate, and rivet head is seated tightly against riveted surface. If rivet is loose or improperly installed, remove it and install a new one.

(2) *Removal. (Figure 3-5)*

**WARNING**

Drilling creates metal chips which may enter eyes and cause serious injury. Eye protection is required.

**NOTE**

When drilling through rivet head, be careful to avoid enlarging hole in structure. Keep drill perpendicular to material being drilled and do not exert excessive pressure on drill, or replacement rivets will be too loose.

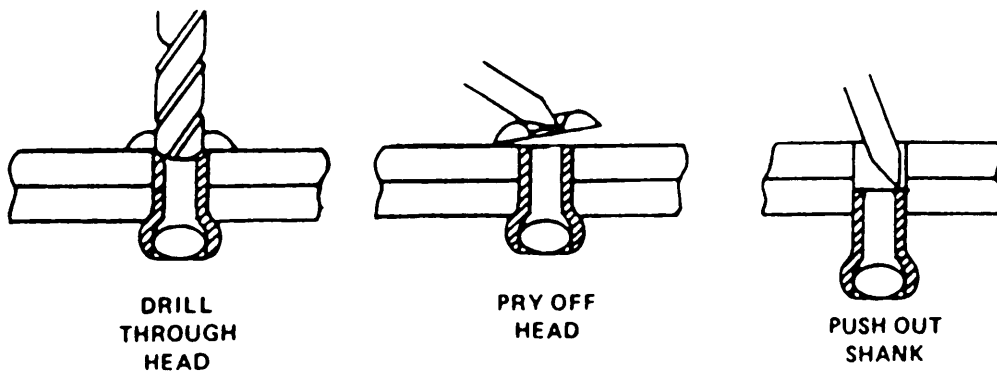

*Figure 3-5. Removing Blind Rivets.*

**3-9. General Repair Procedures (cont).**

(a) Drill through head of rivet only, using hole in rivet as a guide. Use proper drill size as follows:

Rivet Size (in.)	Drill size
1/8	No. 30
5/32	No. 20
3/16	No. 11
1/4	1/4 inch

(b) Using a pin punch, pry off rivet head.

**CAUTION**

Do not punch rivet shanks out as you may damage the other side of the panel.

(c) Using pin punch, push out remainder of rivet shank. If shank will not push out easily, drill it out.

b. Rivnut Installation and Removal. Rivnuts (threaded inserts) are tubular rivets with internal threads and are used throughout the shelter wherever blind threads are required. The types of rivnuts used in the shelter are shown in Figure 3-6 and described in Table 3-3. Flat head rivnuts (style D and E) may be used wherever head thickness will not interfere with installation of equipment. Countersunk head rivnuts (style C) are used for flush installation. Keyed rivnuts are used in locations which are subject to vibration and torque. Closed end rivnuts (styles C and E) must be used for exterior repairs and floor repairs to keep moisture and dirt from entering panels. Open end rivnuts (style D) may be used in areas where sealing is not required.

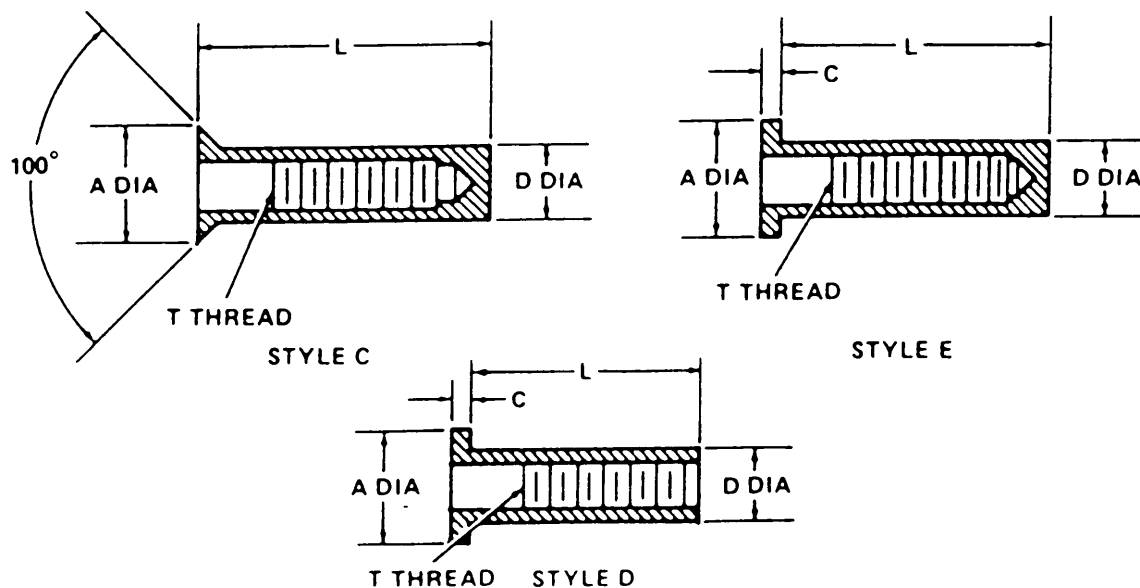

Figure 3-6. Rivnuts (Threaded Inserts).

**3-9. General Repair Procedures (cont).**

*Table 3-3. Rivnuts.*

Part No.	Style	Dim A	Dim D	Dim L	T	Dim C	Grip Range
S31B125CS1	E	0.665	0.413	1.187	5/16-18 UNC-3B	0.062	.030-.125
S31B425CS1	E	0.665	0.413	1.531	5/16-18 UNC-3B	0.062	.350-.425
SS8B120	E	0.357	0.221	0.500	8/32 UNC-3B	0.032	.075 -.120

(1) *Installation.* (Figure 3-7)

**NOTE**

When installing new rivnut in same location as a rivnut that has been removed, if diameter of hole in structure has been enlarged during removal, use next larger diameter rivnut for replacement.

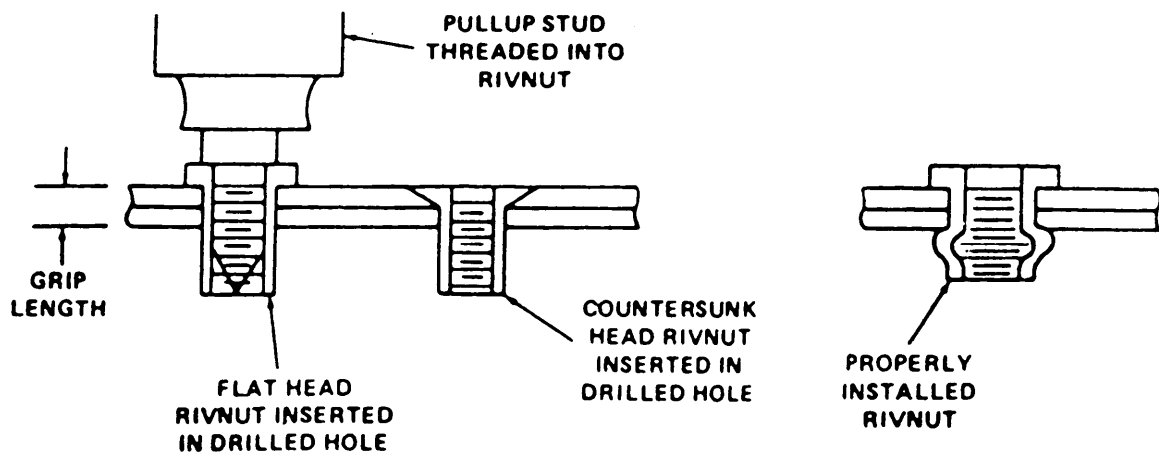

Figure 3-7. Installing Rivnuts.



**3-9. General Repair Procedures (cont).**

- (a) Determine thread size, grip range, style, and material of rivnut to be used. Grip length equals combined thickness of materials being fastened together. Grip range of rivnuts must encompass grip length.

**WARNING**

Drilling creates metal chips which may enter eyes and cause serious injury. Eye protection is required.

**CAUTION**

Do not drill deeper than necessary to install rivet as you may drill through other side of panel.

**NOTE**

Drill hole size must match size of rivnut being installed. Quantities of sheets may be drilled at the same time when held together with sheet fasteners.

- (b) Drill hole in structure.
- (c) Remove all metal chips and remove burrs from drilled holes.
- (d) If a countersunk head rivnut is being installed, countersink hole using a 100-degree machine countersink.
- (e) Thread stem of appropriate pullup stud into rivnut. Stud should protrude through open end rivnuts, or be 1 1/2 threads from bottoming in closed end rivnuts.
- (f) Coat rivnut body with sealer (Item 28, Appendix D) before installing.
- (g) Insert rivnut in hole. Make sure sheets are held tightly together before pulling.
- (h) With pullup stud parallel to axis of rivnut, pull up on rivnut. Exert firm pressure but do not bend or buckle metal sheets.
- (i) Make sure fastened parts are not loose, rivnut does not rotate and rivnut head is seated tightly against surface. Make sure rivnut threads are in good condition. If threads are damaged or rivnut is improperly installed, remove it and install a new one.

**3-9. General Repair Procedures (cont).**

(2) *Removal.* (Figure 3-8)

**WARNING**

Drilling creates metal chips which may enter eyes and cause serious injury. Eye protection is required.

(a) Drill through head of rivnut, using same size drill used to make original hole. Counterbore in rivnut will act as a drill guide.

(b) Remove head of rivnut.

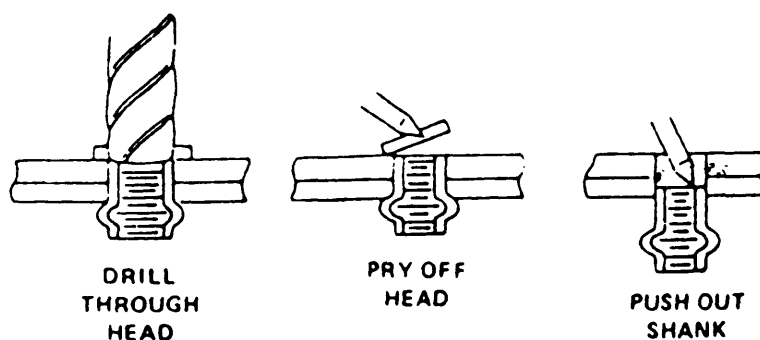

Figure 3-8. Removing Rivnuts.

**CAUTION**

Do not puncture opposite face sheet of panel when punching out rivnut shank.

(c) Punch out shank of rivnut, using a pin punch slightly smaller than hole in structure. Punch only enough to disengage. Move rivnut aside to install new rivnut.

(3) *Repair.* (Figure 3-9) When excessive torque is applied on screws attached on rivnuts, it may cause a rivnut to turn (spin). Table 3-4 provide the maximum torque requirement for hardware to prevent rivnut turning. To correct a turning rivnut, proceed as follows:

(a) Drill a .062 (+.003, -.001) diameter hole by 1.00 inch long on the stem of the turning rivnut as shown in Figure 3-9.

(b) Install a headless straight pin (Item 25, Appendix D) in hole.

**3-9. General Repair Procedures (cont).**

*Table 3-4. Maximum Torque Requirement for Rivnut Screws.*

Screw Size	Torque (lbs/inch)
4 - 40	8 inch lb
6 - 32	12 inch lb
8 - 32	20 inch lb
10-32	20 inch lb
1/4 - 20	50 inch lb
5/16-18	65 inch lb
3/8 - 16	120 inch lb

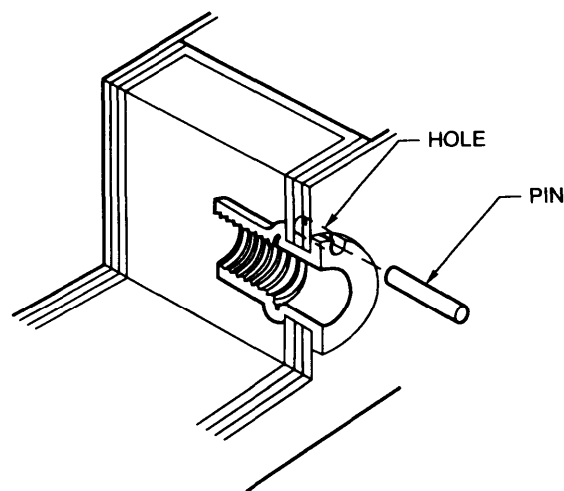

*Figure 3-9. Repair of Turning Rivnut*

c. Temporary Panel Repair. Any puncture in the shelter exterior, including punctures in the door skin, must be patched immediately to prevent water intrusion. Dents without punctures do not require patching. However, if bare metal is exposed, touch-up paint shall be applied (paragraph 3-28).

- |                  |   |   |
|------------------|---|---|
| Materials/Parts: | Adhesive (Item 30, Appendix D)                | Sealer, Silicone (Item 26, Appendix D)    |
|                  | Tape, Polyethylene (Item 29, Appendix D)      | Clean Cloth, Cotton (Item 10, Appendix D) |
|                  | Sandpaper, Grit Nos. 60 (Item 15, Appendix D) | Solvent (Item 9, Appendix D)              |
|                  |   | Gloves (Item 1, Appendix D)               |

**3-9. General Repair Procedures (cont).****WARNING**

Solvents are flammable and toxic. Keep away from heat and open flames. Use in a well-ventilated area. Avoid skin and eye contact and breathing of vapors. Use protective goggles and gloves.

**CAUTION**

Paint strippers can contaminate panel core, adhesive, and sealers. Do not use paint strippers to remove paint.

**NOTE**

Ceiling and floor panel compositions are the same as wall panel composition. The same method of repair applies to all panels.

- (1) Bend edges of puncture in below surface of unbroken face sheet. Do not allow broken edges to contact opposite face sheet.
- (2) Remove loose fragments of foam and dust.
- (3) Clean and dry area surrounding puncture using clean cloth soaked with solvent. Wipe off solvent.
- (4) Inject adhesive into puncture.
- (5) Apply a bead of adhesive approximately 1/4 inch wide over cuts in face sheet. Do not smooth out.
- (6) Plan application of tape. Length and width, number of strips, overlaps, and method of application will affect sealing capability of repair. Each piece of tape shall extend approximately 1-1/2 inches beyond adhesive. Tape must be applied to bare clean metal. If width of damaged area exceeds width of tape, overlap tape strips at least 1/2 inch. If three or more strips of tape are required, apply center strip first.
- (7) Hold tape taut and apply lightly. Do not apply with rolling motion from end to end or side to side and do not rub strips into place. Tape strips must tightly adhere to each other. Rolling, rubbing, and excessive pressure will squeeze adhesive out from under tape.
- (8) Touch up with paint as required (paragraph 3-28).

**3-10. Shelter Assembly.** Shelter Assembly maintenance consists of the following:

- a. Overall shelter assembly inspection (paragraph 3-11).
- b. Drip molding (above door) inspection and repair (paragraph 3-12),
- c. Hand hold (roof) inspection and repair (paragraph 3-13).

**3-10. Shelter Assembly (cont).**

- e.* T-Latch (door) inspection and repair (paragraph 3-14),
- f.* Floor drain inspection and repair (paragraph 3-15).
- g.* Plates (paragraph 3-16).

---

**3-11. Overall Shelter Assembly.**

---

This task covers:       Inspect

---

**INITIAL SETUP***Tools*

General Mechanic's Automotive Tool Kit

---

*Inspect.* (Figure 3-10)

- (1) Inspect shelter exterior for dents, punctures, or any other damage.
- (2) Inspect shelter exterior for missing or loose parts and mounting hardware.
- (3) Inspect door assembly (1) for ease of operation.
- (4) Inspect emergency exit panel assembly (2) for missing or damaged hardware and for ease of removal.
- (5) Inspect hand hold (3) and recessed steps (4) on shelter exterior for loose, missing, or damaged parts, and for proper operation.
- (6) Inspect towing eye assembly (5) for damaged or missing parts and for proper operation.
- (7) Inspect lifting and tiedown eye assembly (6) for damaged or missing parts, and for proper operation.
- (8) Inspect hold down assembly for damaged or missing parts, and for proper operation.
- (9) Inspect roller latch assembly (8), keeper assembly (9), and door brace assembly (10) for damaged or missing parts, and for proper operation.
- (10) Inspect skid assembly (7) for damaged or missing parts.

---

3-11. Overall Shelter Assembly (cont).

---

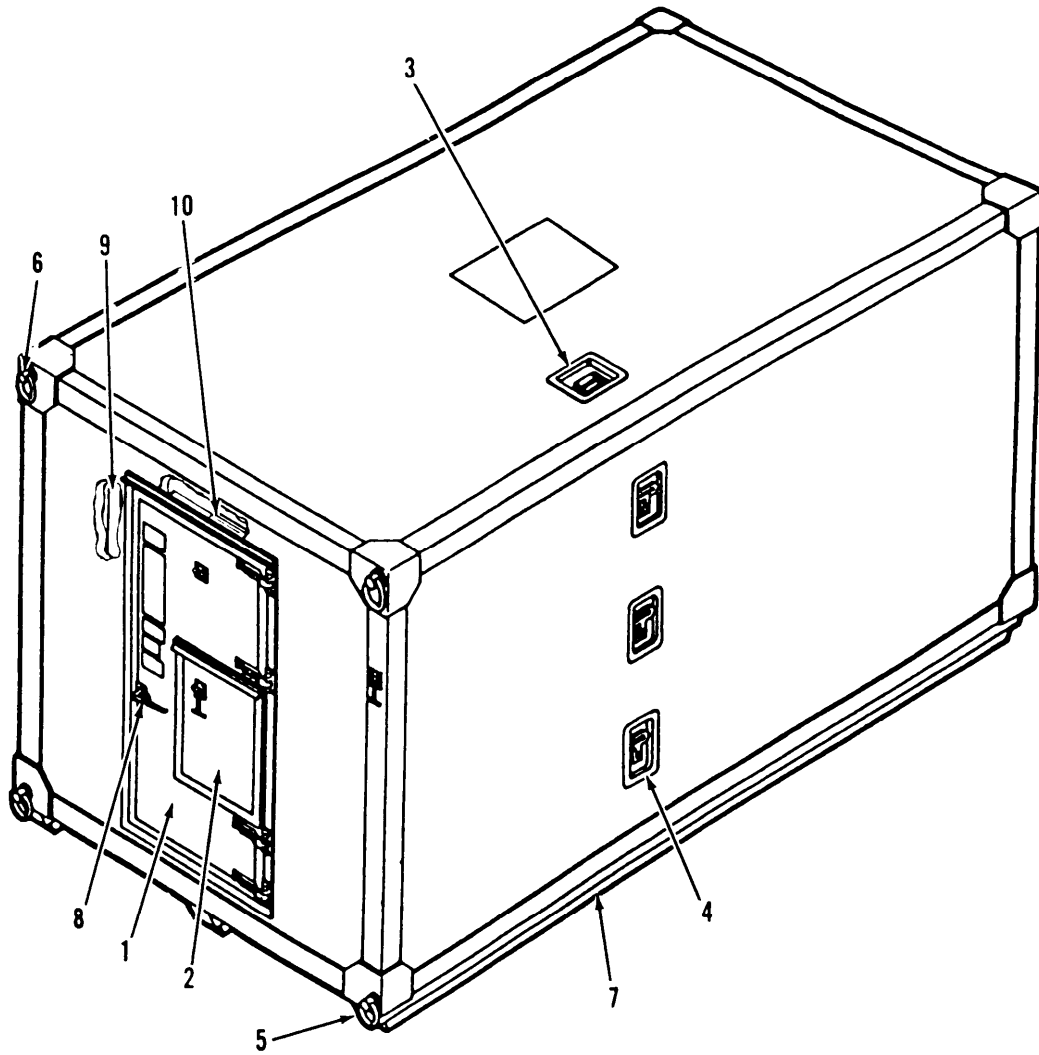

Figure 3-10. Overall Shelter Assembly Inspection.

---

### 3-12. Drip Molding (Above Door).

---

This task covers:           a. Inspect  
                                      b. Repair

---

#### INITIAL SETUP

##### *Tools*

General Mechanic's Automotive Tool Kit  
Blind Riveter

##### *Materials/Parts*

Sealer (Item 28, Appendix D)  
Blind Rivets

---

- a. Inspect. (Figure 3-11)
  - (1) Inspector damaged drip molding (2).
  - (2) Inspector missing blind rivets (1).
  
- b. Repair. Repair of the drip molding consists of replacement of the missing, damaged, or defective parts, as necessary, according to the following procedure:
  - (1) Remove seven blind rivets (1) securing drip molding (2) to shelter. (Refer to paragraph 3-9.a. for rivet removal instructions.)
  - (2) Remove drip molding.
  - (3) Position new drip molding (2) on shelter so that mounting holes line up.
  - (4) Fasten with seven blind rivets (1). (Refer to paragraph 3-9a. for rivet installation instructions.)
  - (5) Apply a continuous bead of sealer around edge of drip molding.

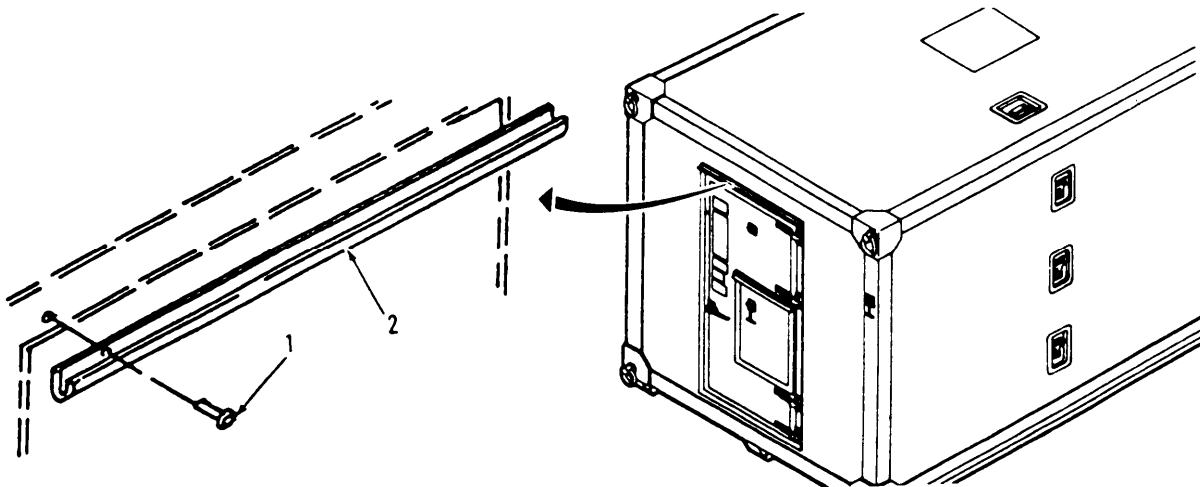

Figure 3-11. Drip Molding Removal/Installation.



---

**3-13. Hand Hold (Roof).**

---

This task covers:

- a. Inspect
- b. Repair

---

INITIAL SETUP

*Tools*

*Materials/Parts*

General Mechanic's Automotive Tool Kit  
Blind Riveter

Sealer (Item 28, Appendix D)  
Blind Rivets, Various

---

a. Inspect. (Figure 3-12)

- (1) Inspect for damaged or non-functioning bail handle (5).
- (2) Inspector missing blind rivets (1, 2, and 4).

b. Repair. Repair of the hand hold consists of replacement of the missing, damaged, or defective parts, as necessary, according to the following procedure:

**NOTE**

■ If only bail handle (5) is damaged, perform steps (2) and (3) below.

- (1) Remove three blind rivets (1) and seven blind rivets (2) securing hand hold (3) to roof of shelter and remove hand hold. (Refer to paragraph 3-9.a. for rivet removal instructions.)
- (2) Drill out five rivets (4) securing bail handle (5) to hand hold (3) and remove bail handle.
- (3) Secure bail handle (5) to hand hold (3) with five rivets (4). (Refer to paragraph 3-9a. for rivet installation instructions.)
- (4) Place hand hold at proper position on shelter roof.
- (5) Attach hand hold (3) to shelter roof with three blind rivets (1) and seven blind rivets (2).
- (6) Apply a continuous bead of sealer around edge of bail handle and edge of hand hold pan.

---

**3-13. Hand Hold (Roof) (cont).**

---

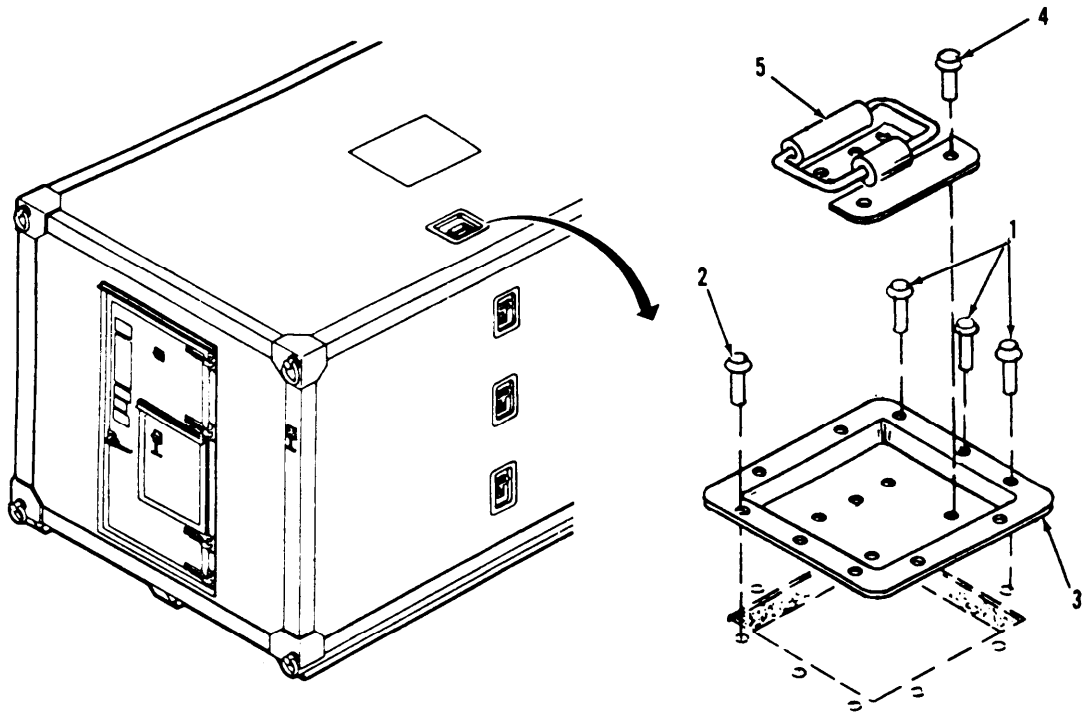

*Figure 3-12. Hand Hold Replacement.*

**3-14. T-Latch Assembly.**

- This task covers:
- a. Inspect
  - b. Repair

INITIAL SETUP

*Tools*

General Mechanic's Automotive Tool Kit  
Blind Riveter

*Materials/Parts*

Sealer (Item 28, Appendix D)  
Blind Rivets

a. Inspect. (Figure 3-13)

- (1) Inspect damaged T-latch assembly (2).
- (2) Inspect latch assembly holder (7) for damage and secure mounting.

b. Repair. Repair of the T-latch assembly consists of replacement of the missing, damaged, or defective part, as necessary, according to the following procedure:

- (1) Remove four blind rivets (1) securing T-latch assembly (2) to shelter and remove T-latch. (Refer to paragraph 3-9.a. for rivet removal instructions.)
- (2) Remove and retain four phillips head screws (3), flat washers (4), lock washers (5), and nuts (6) attaching T-latch holder (7) to door panel and remove holder.

**NOTE**

All screws must be dipped in sealer prior to installation.

- (3) Position new holder (7) in place on door panel and secure with four phillips head screws (3), flat washers (4), lock washers (5), and nuts (6).
- (4) Secure T-latch assembly (2) with four blind rivets (1). (Refer to paragraph 3-9a for rivet installation instructions.)
- (5) Apply a bead of sealer around edge of T-latch assembly and T-latch holder.

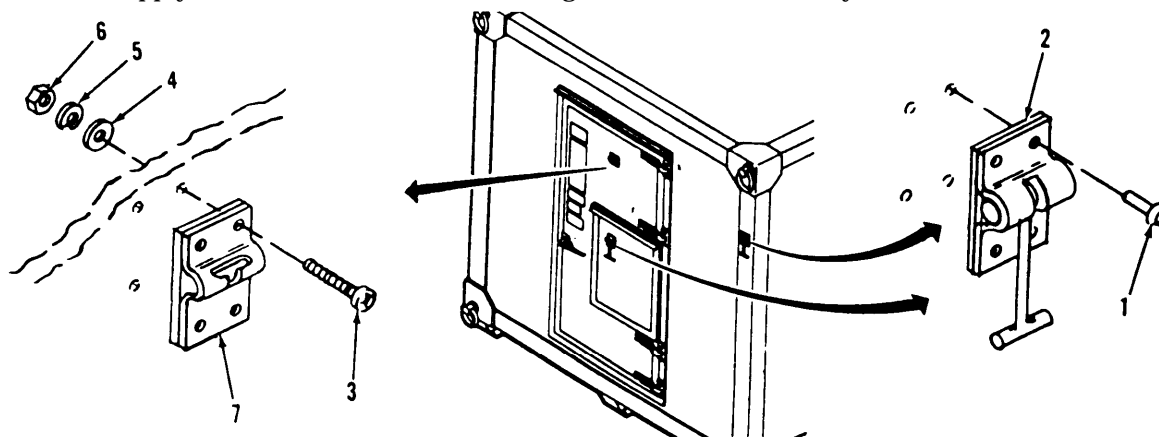

Figure 3-13. T-Latch Replacement.

---

### 3-15. Drain Plug.

---

This task covers:

- a. Inspect
- b. Repair

---

#### INITIAL SETUP

##### *Tools*

General Mechanic's Automotive Tool Kit  
Blind Riveter

##### *Materials/Parts*

Sealer (Item 28, Appendix D)  
Blind Rivets, Various

---

a. Inspect. (Figure 3-14)

- (1) Inspect the drain plug (5) for wear, damage, and secure mounting.
- (2) Inspect the drain tube (3) for damage.
- (3) Inspect the pan (7) and plate (2) for damage and secure mounting.

b. Repair. Repair of the drain plug installation consists of replacement of the missing, damaged, or defective part, as necessary, according to the following procedure:

#### **WARNING**

Prior to attempting to perform maintenance on the underside of the floor, ensure that shelter is supported properly to prevent injury to personnel.

#### **CAUTION**

The shelter should be raised and supports placed under the outside skids, approximately two feet above ground.

- (1) Remove four blind rivets (1) attaching the plate (2) to the underside of the floor panel. (Refer to paragraph 3-9.a. for rivet removal instructions).
- (2) Remove flare from bottom of tube (3), push tube up and remove tube (3) and plate (2).
- (3) Remove rivet (4) attaching the drain plug and chain (5) and four rivets (6) attaching the drain pan (7) to floor and remove pan.
- (4) Place drain pan (7) in position and secure with four rivets (6). (Refer to paragraph 3-9.a. for rivet installation instructions.)

---

**3-15. Drain Plug (cont).**

---

- (5) Position plate (2) with the chamfer facing down over the drain hole on the underside of the floor panel and secure using four rivets (1).
- (6) Insert drain tube (3) in hole and flare the end of the tube touching the plate (2) against the chamfer of the plate (2).
- (7) Place drain plug (5) in drain and secure drain plug chain with rivet (4) to pan (7).
- (8) Apply sealer to joints, edges and joining surfaces of the pan, tube, and plate.

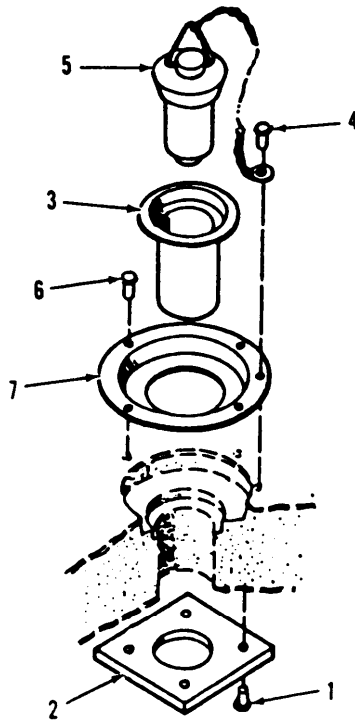

*Figure 3-14. Drain Replacement.*

**3-16. Plates.**

This task covers:

- a. Inspect
- b. Repair

## INITIAL SETUP

*Tools*

General Mechanic's Automotive Tool Kit  
Blind Riveter  
Rivnut Installation Tool

*Materials/Parts*

Blind Rivets, Various  
Rivnuts, Various  
Sealer (Item 28, Appendix D)

a. Inspect. (Figure 3-15)

- (1) Inspect shelter for missing data plates.
- (2) Inspect data plates for legibility.
- (3) Check for missing rivets.

b. Repair. Repair of the data plates consists of replacement of the missing, damaged, or defective part, as necessary, according to the following procedure:

- (1) Remove four rivnuts (1) attaching the aircraft loading data plate (2) at the top of the door (Refer to paragraph 3-9.b. for rivnut removal instructions).
- (2) Place the aircraft loading data plate (2) in place and secure to door with four rivnuts (1) (Refer to paragraph 3-9.b. for rivnut installation instructions).

**NOTE**

The following procedures are similar for all other data plates in this shelter.

- (3) Remove four blind rivets (3) securing data plate (4) to shelter surface and remove plate. (Refer to paragraph 3-9.a. for rivet removal instructions.)
- (4) Place data plate (4) in place on door and secure with four blind rivets (3). (Refer to paragraph 3-9.a. for rivet installation instructions.)

---

3-16. Plates (cont).

---

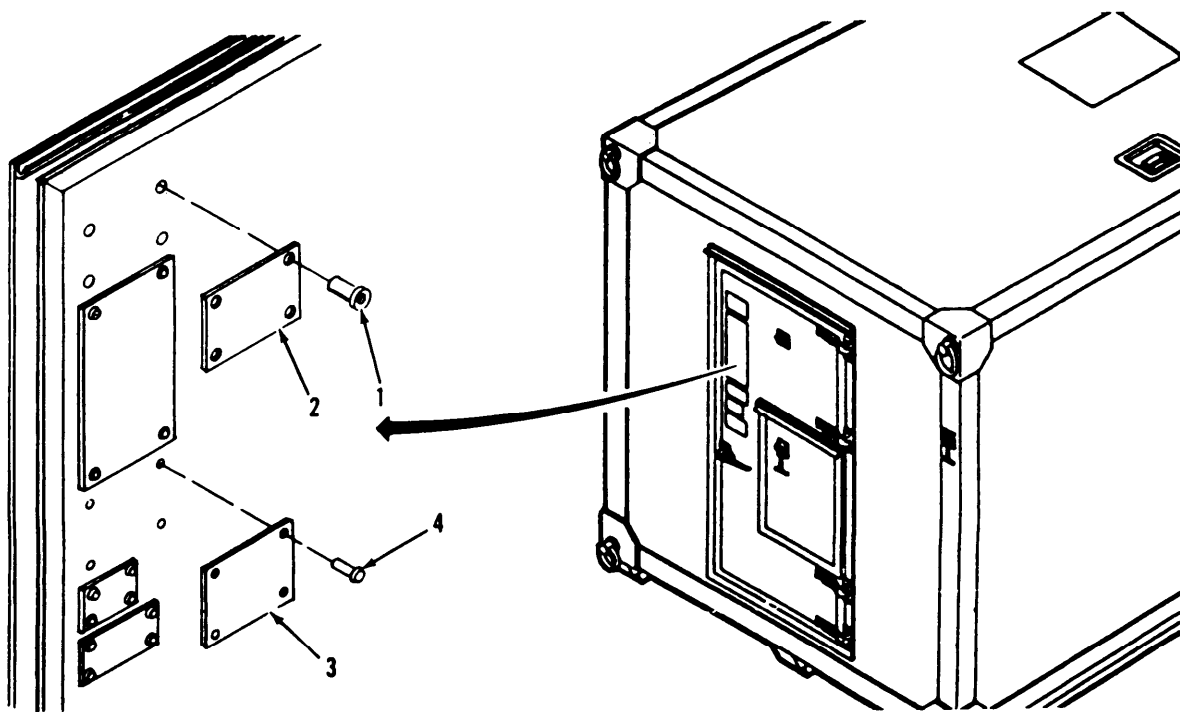

Figure 3-15. Data Plate Replacement.

---

### 3-17. Hinge Assembly.

---

This task covers:	a. Inspect	d. Assemble
	b. Remove	e. Install
	c. Disassemble	

---

#### INITIAL SETUP

##### *Tools*

##### *Materials/Parts*

General Mechanic's Automotive Tool Kit

Sealer (Item 28, Appendix D)

---

- a. Inspect. (Figure 3-16)
  - (1) Inspect hinge for ease of movement.
  - (2) Inspect for cracks or dents.
  - (3) Inspect secure mounting.
- b. Remove. (Figure 3-16)
  - (1) Remove and retain two bolts (1) and a bolt (2), three flat washers (3), and three nuts (4) attaching the hinge body (13) to door panel.
  - (2) Remove and retain two bolts (5), flat washers (6), and nuts (7) attaching the hinge butt plate (12) to shelter, and remove hinge and shims (8 and 9).
- c. Disassemble.
  - (1) Remove spring pin (10) attaching hinge pin (11), and push hinge pin (11) out of hinge butt plate (12).
  - (2) Remove hinge body (13) and two hinge washers (14) from hinge butt plate (12).
- d. Assemble.
  - (1) Position hinge washers (14) and hinge body (13) in place on hinge butt plate (12). and secure by inserting hinge pin (11) into hinge butt plate (12).
  - (2) Attach spring pin (10) to hinge body (13) to secure hinge pin (11).
- e. Install.

#### NOTE

Coat shafts and underside of bolt heads with sealer before installing bolts (1, 2 and 5).

- (1) Position shims (8 and 9) and hinge butt plate in place on shelter wall and secure to shelter with two bolts (5), flat washers (6) and nuts (7).



---

**3-17. Hinge Assembly.**

---

- (2) Push hinge body (13) flat against door panel and secure to door with two bolts (1), a bolt (2), three flat washers (3), and three nuts (4).
- (3) Apply a continuous bead of sealer around edge of hinge butt plate ad hinge body, and cover bolt heads with sealer.

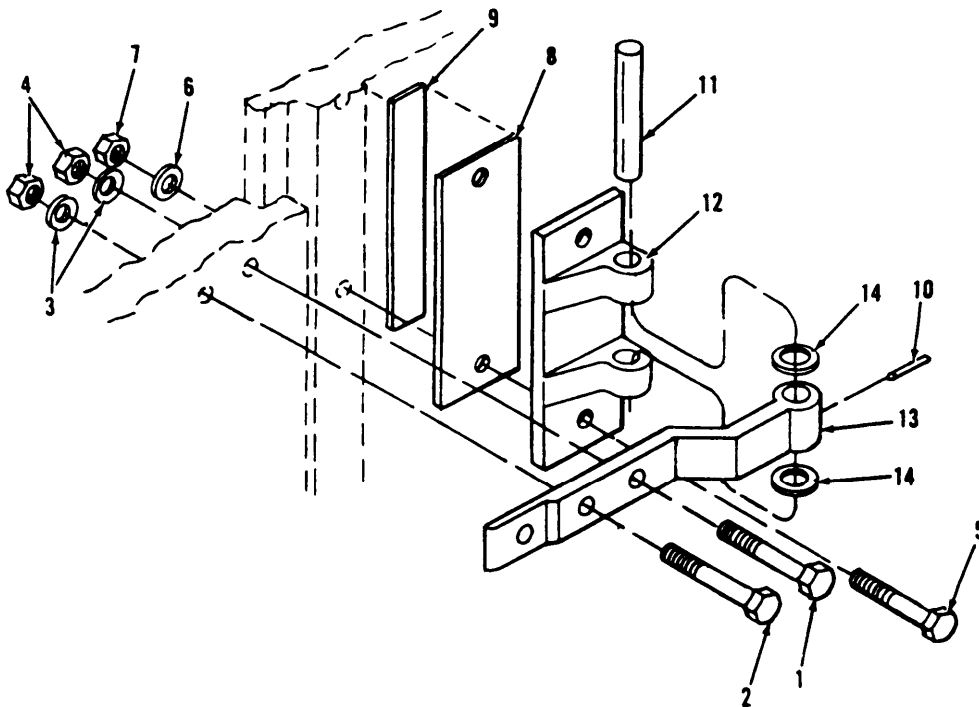

*Figure 3-16. Hinge Assembly Replacement.*

---

### 3-18. Door Assembly.

---

This task covers:	a. Inspect	e. Disassemble
	b. Test	f. Assemble
	c. Adjust	g. Install
	d. Replace	h. Repair

---

#### INITIAL SETUP

##### *Tools*

General Mechanics Automotive Tool Kit  
Blind Riveter

##### *Materials/Parts*

Sealer (Item 28, Appendix D)  
Silicone Sealer (Item 26, Appendix D)  
Gasket, Silicone (Item 27, appendix D)  
Blind rivets, Various  
Shield, EM (Item 32, appendix D)

---

a. Inspect. (Figure 3-20)

- (1) Inspect the door assembly (2) for external damage.
- (2) Inspect the silicone weather gasket (15) for tightness.
- (3) (Shielded) Inspect the EM gasket (1.1) for damage and secure mounting.
- (4) Inspect the door for positive closing and proper operation.
- (5) Inspect the knob assemblies (1) for tightness for securing the emergency exit panel (2) to door panel.

b. Test. (Figure 3-17) Test of the door assembly consists of testing for proper seal pressure on the silicone weather gasket. The procedure listed below shall be performed at the center top and bottom of the door; 1/2 inch from each corner; and along the sides of the door in 2 places (approximately 1/3 and 2/3 the height of the door), as shown in Figure 3-17.

- (1) Place a single piece of paper (0.005 inches maximum thickness by 2-1/2 inches wide) between the silicone weather gasket and its bearing surface.
- (2) Close and lock the door.

#### NOTE

The absence of any resistance to the withdrawal of the paper indicates that the gasket is not touching its bearing surface, thus indicating insufficient pressure.

- (3) Withdraw the paper. Resistance to the withdrawal of the paper indicates proper seal pressure. If there is no resistance, perform the adjustment procedure contained in the following paragraphs.

---

**3-18. Door Assembly (cont).**

---

- (4) If there is resistance to the withdrawal at all of the test points, sufficient seal pressure exists on the silicone weather gasket, and adjustments are not necessary.

c. Adjust. (Figure 3-18) Adjustment to increase the seal pressure on the silicone weather gasket can be made on the hinged side of the door and on the roller latch side of the door, as described in the following paragraphs:

- (1) Weather Gasket Pressure Adjustment (Hinge Side). To increase the weather gasket pressure on the hinged side of the door, proceed as follows:
- (a) Open the door and remove and retain three bolts (1), flat washers (2), and self-locking nuts (3) attaching the hinge to the door.
  - (b) Insert shim (4), approximately 0.032 inches thick and matching the hinge body in size, between the hinge body and the door.
  - (c) Secure the hinge body to the door using three bolts (1), flat washers (2), and self-locking nuts (3).
  - (d) Repeat the test procedures of paragraph 3-17.b. and repeat this adjustment procedure as necessary.
- (2) Weather Gasket Pressure Adjustment (Latch Side). To increase the weather gasket pressure on the roller latch side of the door, proceed as follows:
- (a) Open the door and remove and retain the hex head screws (5 and 6) and lock washers (7) from the top and bottom hole attaching the keeper (8) to the wall, and remove keeper and shim (9). Remove detent pin (10) from center keeper.

**NOTE**

If more than one shim is required, additional shims may be added, up to a maximum thickness of 0.096 inches.

If the seals are not tight after the maximum allowable thickness is obtained, the seal should be replaced as the material has likely broken down.

- (b) Add a 0.032 inch shim between the keeper (8) and the shelter.
- (c) Repeat the seal pressure test of paragraph 3-17.b. If the seal pressure remains insufficient, add another 0.032 inch shim.
- (d) Repeat this process until sufficient seal pressure is developed or until the maximum allowable thickness is obtained.

3-18. Door Assembly (cont).

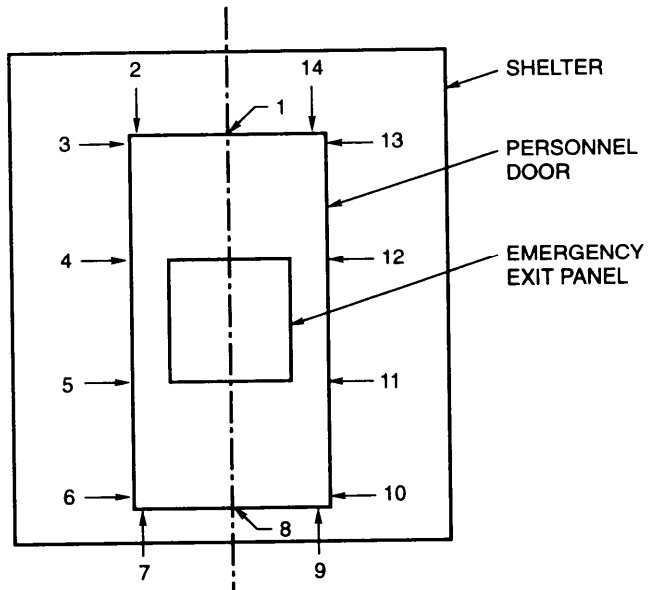

Figure 3-17. Typical Locations for Door Gasket Testing.

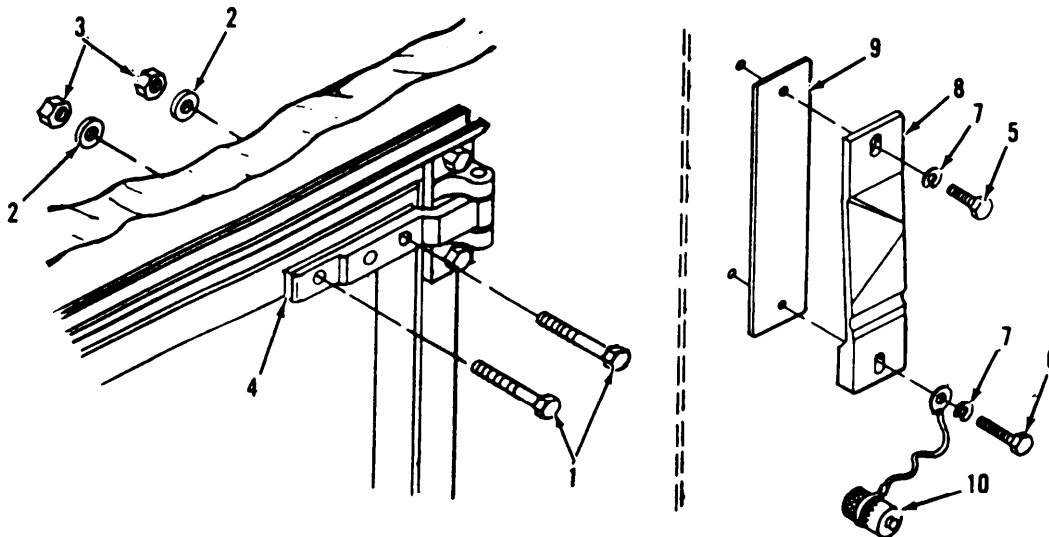

Figure 3-18. Weather Gasket and Seal Pressure Adjustment.

---

**3-18. Door Assembly (cont).**

---

d. *Remove.* (Figure 3-19)

- (1) Remove and retain ten phillips head screws (1) attaching the door stop bracket (2) to inside of the door, and a phillips head screw (3) attaching the chain end.
- (2) Remove and retain the two 5/16-24 x 2-27/32 bolts (4), one 5/16-24 x 2-23/32 bolt (5), three flat washers (6), and three self-locking nuts (7) attaching each of the four hinges (8) to door.

**WARNING**

To prevent damage to door or injury to personnel, use extreme care in lifting and carrying door.

- (3) Turn door handle to open position and remove door. For disassembly instructions to remove the door latch assembly, refer to paragraph 3-20.

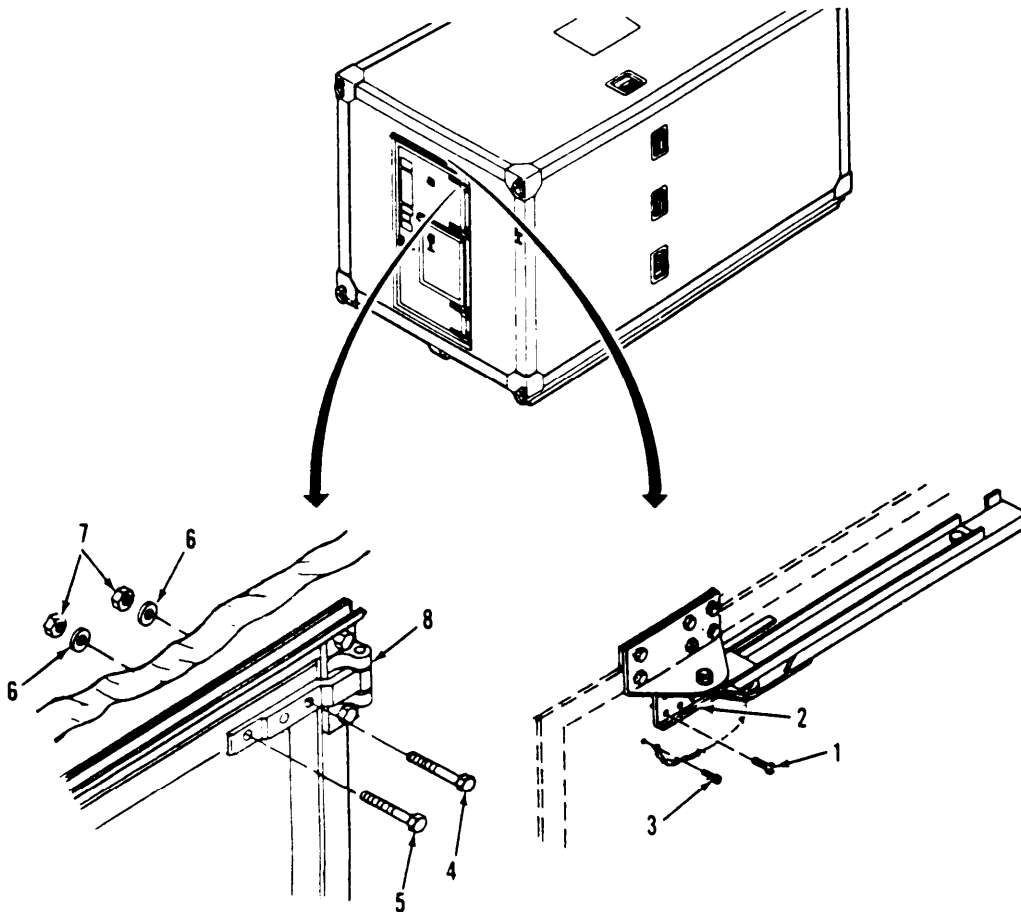

**Figure 3-19. Door Assembly Replacement**

---

**3-18. Door Assembly (cont).**

---

**e. Disassemble.** (Figure 3-20)

- (1) Turn each of the four knob assemblies (1) counterclockwise to release the emergency exit panel (2) and remove panel from door (3).
- (2) Remove rivet (4) attaching the knob assembly chain (4) to retainer bracket (5) and remove knob. Refer to paragraph 3-9.a. for rivet removal.
- (3) Remove two rivets (6) attaching each air inlet panel retainer (5) to door panel (2) and remove retainers.
- (4) Remove 17 rivets (7) attaching the drip moulding (9) to door and remove drip moulding (9) and drip cap strip (8).
- (5) Remove and retain four phillips head screws (10), flat washers (11), lock washers (12), and nuts (13) attaching each T-latch holder (14) to door (3) and remove holder (14).
- (6) Remove the silicone weather gasket (15) and clean any adhesive residue from track.
- (7) (Shielded) Remove the EM shield (15.1).

**f. Assemble.** (Figure 3-20)**CAUTION**

Allow at least 30 minutes cure time for adhesive before using door.

- (1) Apply RTV 138 silicone sealer in track groove all around door and snap new gasket (15) in place in track on door (3).
- (2) (Shielded) Clean the EM shield track of any dirt, place a new shield (15.1) over the track and snap into place.

**NOTE**

Dip screws in sealer prior to installation.

- (3) Position T-latch holder (14) in place on door panel (3) and secure with four phillips head screws (10), flat washers (11), lock washers (12), and nuts (13).
- (4) Place drip moulding (9) and drip cap strip (8) on door and secure with 17 blind rivets (7).
- (5) Position each air inlet panel retainer (5) in place on inside of door and secure to door with four blind rivets (6).

**3-18. Door Assembly (cont).**

---

- (6) Screw knob assembly (1) into air inlet panel retainer (5) and secure knob assembly chain to retainer with a blind rivet (4).
- (7) Position Emergency exit panel (2) in place on door opening and secure to door (3) by turning the four knob assemblies (1) clockwise.
- (8) Apply a continuous bead of sealer around the mating surface of the T-latch holder (14) and air inlet panel retainers (5) to door.

**g. Install.** (Figure 3-19)

- (1) For assembly instructions to secure the roller latch assembly on a new door, refer to paragraph 3-20.
- (2) Position door in place and turn door handle to closed position.
- (3) Butt each of the four hinges (8) against the door and secure using two 5/16-24 x 2-27/32 bolts (4), one 5/16-24 x 2-23/32 bolt (5), three flat washers (6), and three self-locking nuts (7).
- (4) Secure the door stop bracket (2) to inside of door using ten phillips head screws (1) and with a phillips head screw (3) secure the chain end.

**h. Repair.** (Figure 3-20) Repair of the door assembly consists of panel replacement and repair of the silicone weather gasket, (Shielded) EM shield, knob assemblies, air inlet panel retainers, drip moulding and T-latch holder.

3-18. Door Assembly (cont).

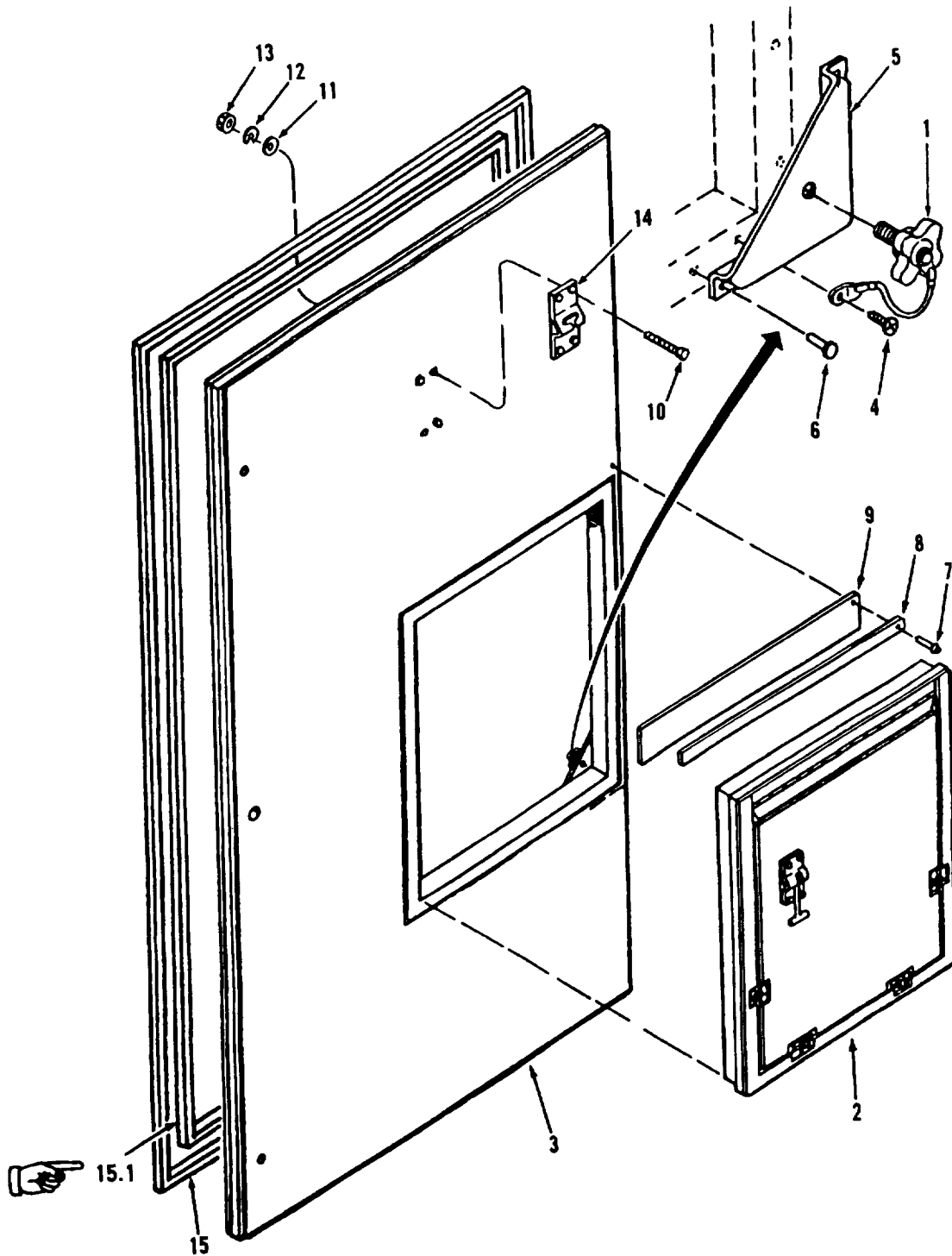

Figure 3-20. Door Assembly Maintenance.



---

**3-19. Emergency Exit Panel Assembly.**

---

This task covers:

a. Inspect	d. Disassemble
b. Test	f. Assemble
c. Remove	g. Install

---

INITIAL SETUP

***Tools***

General Mechanics Automotive Tool Kit  
Blind Riveter

***Materials/Parts***

Sealer (Item 28, Appendix D)  
Silicone Sealer (Item 26, Appendix D)  
Gasket, Silicone (Item 27, appendix D)  
Blind rivets, Various  
Shield, EM (Item 32, appendix D)  
Tape (Item 33, appendix D)  
Filter - RF (Item 34, appendix D)

---

a. Inspect. (Figure 3-22)

- (1) Inspect the panel for external damage.
- (2) Inspect the silicone weather gasket (1) located on the outside track on the inside periphery of the panel, and weather gasket (2) located on the inside edge of the panel cover.
- (3) (Shielded) Inspect the EM shield (1.1) located adjacent to the silicone weather gasket (1).
- (4) Inspect the air filters (11) for wear and cleanliness.
- (5) (Shielded) Inspect the RFI/EMI filter (17.1).
- (6) Inspect the four latches (5) for wear and secure mounting.
- (7) Inspect the intake louver assembly (17) for damage and secure mounting.

b. Test. Test of the emergency exit panel consists of testing for proper seal pressure on the silicone weather gasket. The procedure listed below shall be performed at the center bottom; 1/2 inch from each corner; and two places along each side (approximately 1/3 and 2/3 the height of the emergency exit panel) as shown in Figure 3-21.

- (1) Place a single piece of paper (0.005 inches maximum thickness by 2-1/2 inches wide) between the silicone weather gasket and its bearing surface.
- (2) Turn knob assemblies (Item 1, figure 3-20) clockwise and secure emergency exit panel securely to door.

3-19. Emergency Exit Panel Assembly (cont).

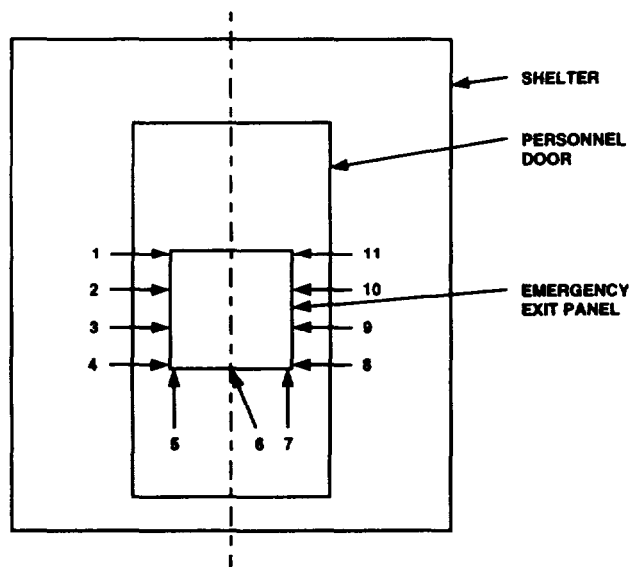

Figure 3-21. Typical Locations for Emergency Exit Panel Gasket Testing

**NOTE**

The absence of any resistance to the withdrawal of the paper indicates that the gasket is not touching its bearing surface, thus indicating insufficient pressure.

- (3) Withdraw the paper. Resistance to the withdrawal of the paper indicates proper seal pressure. If there is no resistance, the seal should be replaced as the material has likely broken down.

- c. Remove. (Figure 3-20)

**WARNING**

To prevent damage to panel or injury to personnel, ensure someone will receive panel on outside of door.

- (1) Turn the four knobs (1) counterclockwise to release emergency exit panel (2).
- (2) Push emergency exit panel (2) to outside and remove.

- d. Disassemble. (Figure 3-22)

- (1) Remove the silicone weather gaskets (1 and 2) from the inside edges of the panel and cover.
- (2) (Shielded) Remove the EM shield (1.1) from the inside edges of the panel.

3-19. Emergency Exit Panel Assembly (cont).

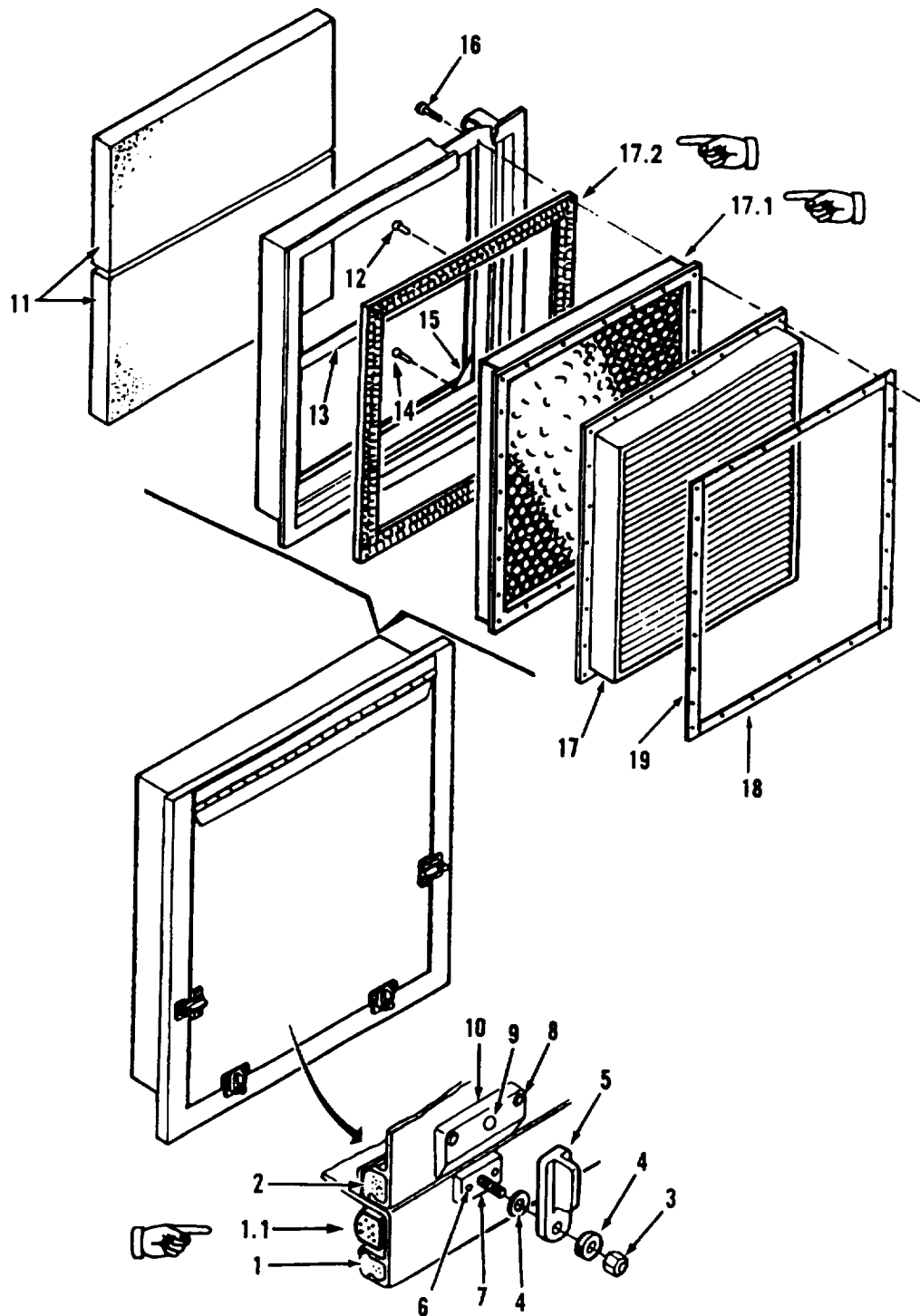

Figure 3-22. Emergency Exit Panel Assembly and (Shielded) RFI/EMI Filter Replacement

---

**3-19. Emergency Exit Panel Assembly (cont).**

---

- (3) Remove and retain nut (3) and two nylon flat washers (4) securing each of the four latches (5) and remove latches.
  - (4) Remove two rivets (6) attaching each of the four stud plate assemblies (7) to panel and remove stud plate. (Refer to paragraph 3-9a. for blind rivet removal instructions.)
  - (5) Remove two rivets (8) and a rivet (9) attaching each of the four strike plates (10) to cover, and remove strikes.
  - (6) Reach behind panel, take hold of each air filter (11), pull out of position and remove.
  - (7) Remove four rivets (12) attaching the divider strip (13) to back of panel and remove strip.
  - (8) Remove two rivets (14) attaching each corner gusset (15) to back of panel and remove gussets.
  - (9) Remove and retain 92 phillips head screws (16) attaching the intake louver assembly (17) and (Shielded) RFI/EMI filter (17.1) to panel frame and remove four retaining strips (18 and 19), louver (17), (Shielded) RFI/EMI filter (17.1), and (Shielded) knitted wire mesh tape (17.2).
  - (10) Remove sealer from retaining strips (18 and 19), louver (17) and panel frame.
- e. Assemble. (Figure 3-22)
- (1) Position (Shielded) knitted wire mesh tape (17.2), (Shielded) RFI/EMI filter (17.1), intake louver assembly (17) and four retaining strips (18 and 19) in place inside panel frame and secure with 92 phillips head screws (16).
  - (2) Position each of the four corner gussets (15) in place on the back of the panel frame and secure each with two blind rivets (14).
  - (3) Position the divider strip (13) in place and secure to panel frame with four blind rivets (12).
  - (4) Insert two air filters (11) in place in back of panel.
  - (5) Place each of the four strike plates (10) in position and secure to panel cover with three blind rivets (8 and 9).
  - (6) Position each of the four stud plate assemblies (7) in place on panel flange and secure each with two blind rivets (6).
  - (7) Place a nylon flat washer (4) over the stud of each stud assembly (7), then a latch (5), and secure in place with a nylon flat washer (4) and nut (3).

**3-19. Emergency Exit Panel Assembly (cont).**

---

- (8) Clean adhesive residue from gasket tracks in panel and cover, and apply RTV 138 silicone sealer in track grooves.

**CAUTION**

Allow at least 30 minutes cure time for the silicone sealer to adhere before using the panel.

- (9) Snap new silicone gaskets (1 and 2) in track on panel and cover flanges.
- (10) (Shielded) Clean EM shield track of any dirt, place a new shield (1.1) over the track and snap in place.
- (11) Apply sealer over retaining strips (18 and 19), screw ends (16), flange of louver (17) and edge of (Shielded) RFI/EMI filter flange (17.1).

**CAUTION**

Leave the exit panel assembly in a horizontal position after application of sealer, until sealer is no longer tacky to the touch (2-3 days).

*f. Install.* (Figure 3-20)

- (1) Position emergency exit panel (2) in opening of door.
- (2) Turn four knobs (1) clockwise to secure emergency exit panel (2) to door (3).

---

**3-20. Door Latch Assembly.**

---

This task covers:	a. Inspect	d. Assemble
	b. Service	e. Repair
	c. Disassemble	

---

INITIAL SETUP

<i>Tools</i>	<i>Materials/Parts</i>
General Mechanic's Automotive Tool Kit	Sealer (Item 28, Appendix D) Solid Film Lubricant (Item 22, Appendix D)

---

- a. Inspect.
  - (1) Inspect the door latch assembly for secure mounting and broken or worn parts.
  - (2) Inspect for ease of operation.
  - (3) Inspect the door handle for tightness and for worn or damaged parts.
- b. Service. (Figure 3-23) Service of the door latch assembly consists of lubricating the door handle (8) and latch arm assemblies (10) with lubricant once per month.
- c. Disassemble. (Figure 3-23)

**NOTE**

Disassembly procedures are similar for top and bottom sections of door latch assembly.

- (1) Punch out spring pin (1) and remove flat washer (2) from latch arm assembly (10).
- (2) Pull pin (3) and push latch rod assemblies (4 and 5) to the side.
- (3) Punch out spring pin (6) attaching the inside handle (7) to outside handle and shaft (8). Remove inside handle (7).
- (4) Punch out grooved pin (9) from underside of latch arm assembly (10) and remove grooved pin (9) to release the latch arm assembly (10). Pull outside handle assembly (8) out of door.
- (5) Remove o-ring (15) from place on outside handle shaft (8).
- (6) Turn the bearing sleeve nut (16) counterclockwise to release the handle shaft sleeve (17) and remove nut (16) and shaft sleeve (17).

**3-20. Door Latch Assembly (cont).**

---

- (7) Punch out spring pin (11) and release the roller extension (12) and roller latch (13) from latch arm (14).
- (8) Punch out spring pin (1) and release flat washer (2), pin (18), and latch rod assembly (4 and 5).
- (9) Remove nut (19) to release washer (20), spacer (21), latch arm assembly (10), spacers (22, 24, and 25), latch arm detent (23), (at the bottom latch installation only), and bolt (26).
- (10) Remove and retain a phillips head screw (27) and lock washer (28) attaching padlock and chain (29) to escutcheon plate (30) and remove padlock.
- (11) Remove and retain two phillips head screws (31) and remove escutcheon plate (30) from door panel.

d. Assemble.

**NOTE**

Assembly procedures are similar for top and bottom sections of door latch assembly.

- (1) Position escutcheon plate (30) in place on door panel and secure with two phillips head screws (31).
- (2) Place mounting end of padlock and chain (29) over mounting hole and secure with a phillips head screw (27) and lock washer (28).
- (3) Place roller extension (12) and roller latch (13) on to latch arm (14) and secure with spring pin (11).

**NOTE**

When installing the latch arm detent (23) at the bottom section of the assembly, have the latch mechanism fully open, so that the raised surface is engaged in the hole of the latch arm assembly (10). Then secure all components by tightening nut (19).

- (4) Place bolt (26) through hole on door and insert spacers (24 and 25), latch arm detent (23), spacer (22), (at top of installation), latch arm assembly (10), spacer (21), and washer (20), and secure with nut (19).
- (5) Put washer (2) onto pin (18), insert pin (18) through hole on rod latch (4 and 5), and secure with spring pin (1).
- (6) Insert handle shaft sleeve (17) into hole from outside of door panel and secure with bearing sleeve nut (16) from the inside of panel.

---

**3-20. Door Latch Assembly (cont).**

---

- (7) Place o-ring (15) on outside handle shaft (8).
  - (8) Insert door handle shaft (8) through handle shaft sleeve (17).
  - (9) Insert latch arm (10) onto door handle shaft (8) and secure with spring pin (9).
  - (10) Place inside handle (7) onto door shaft and secure with spring pin (6).
  - (11) Align holes on latch rod assemblies (4 and 5) with hole on latch arm (10) and insert pin (3) Place washer (2) onto the pin (3) and secure with spring pin (1).
  - (12) Apply a continuous bead of sealer mound head of bolts (26) and periphery of escutcheon plate (30).
- e. Repair. Repair of the door latch consists of replacing defective parts.



3-20. Door Latch Assembly (cont).

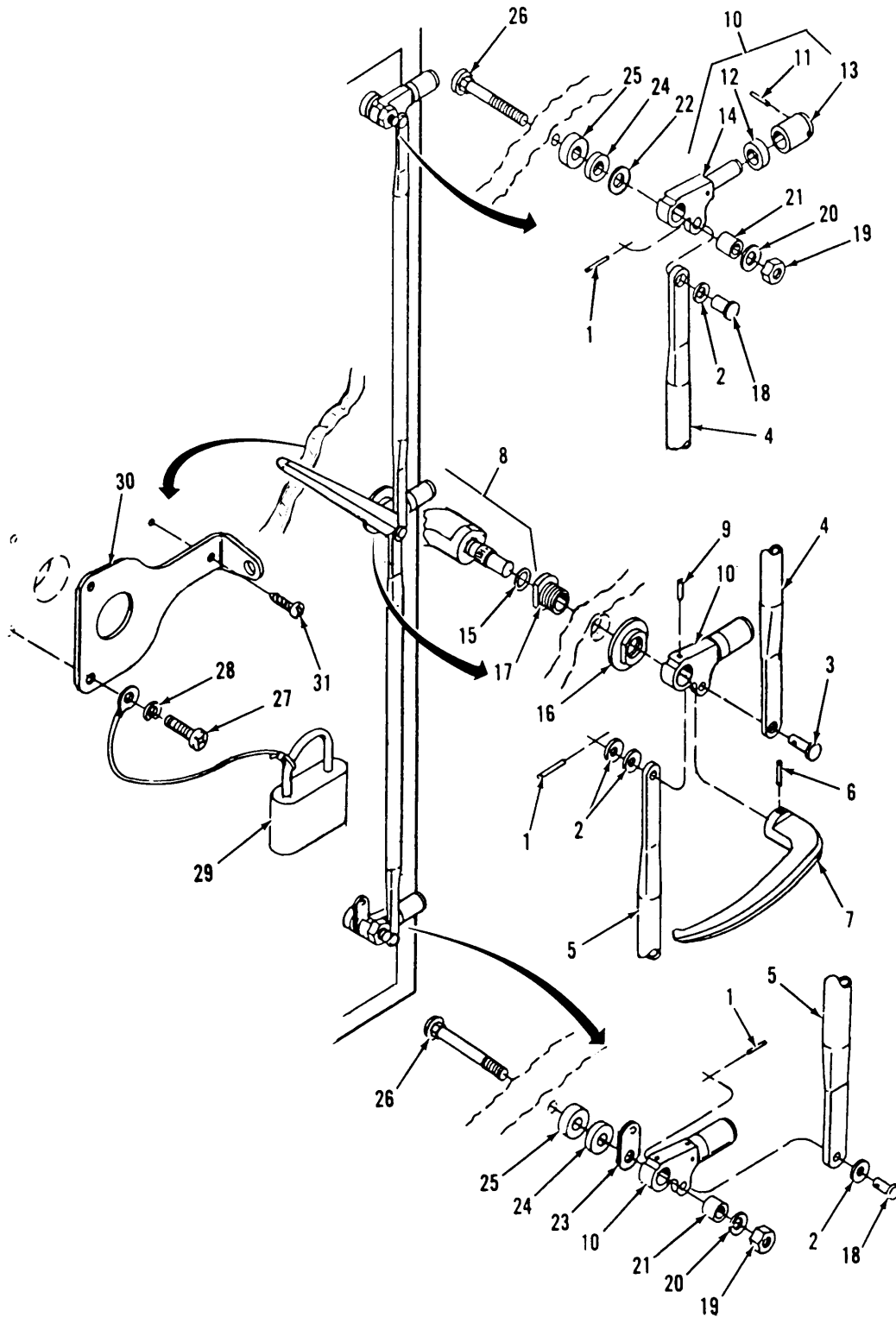

Figure 3-23. Door Latch Replacement

---

**3-21. Keeper Assembly.**

---

This task covers:      a. Inspect  
                                 b. Replace

---

**INITIAL SETUP***Tools**Materials/Parts*

General Mechanic's Automotive Tool Kit

Sealer (Item 28, Appendix D)

---

*a. Inspect. (Figure 3-24)*

- (1) Inspect for wear and other physical damage.
- (2) Inspect for secure mounting.
- (3) Inspect latch lock assembly (3) for wear or damage.

*b. Replace. (Figure 3-24)*

- (1) Remove and retain hex-head screw (1) and lock washer (2) from top (upper) hole of keeper assembly (3).
- (2) Remove and retain hex-head screw (4) and lock washer (2) from bottom (lower) hole of keeper (3) attaching each of the keepers (3) and shim (5) to wall and remove.
- (3) If only latch lock assembly (6) has to be removed, remove and retain hex-head screw (4) and lock washer (2) attaching the center keeper at the bottom (lower) hole.
- (4) Position shim (5), and each keeper (3) in place and secure to shelter wall at top hole using hex-head screw (1) and lock washer (2).
- (5) Secure keeper to wall at bottom hole using hex-head screw (4) and lock washer (2).
- (6) If only latch lock assembly (6) has to be installed, position in place over bottom mounting hole of center keeper and secure using hex-head screw (4) and lock washer (2).

3-21. Keeper Assembly (cont).

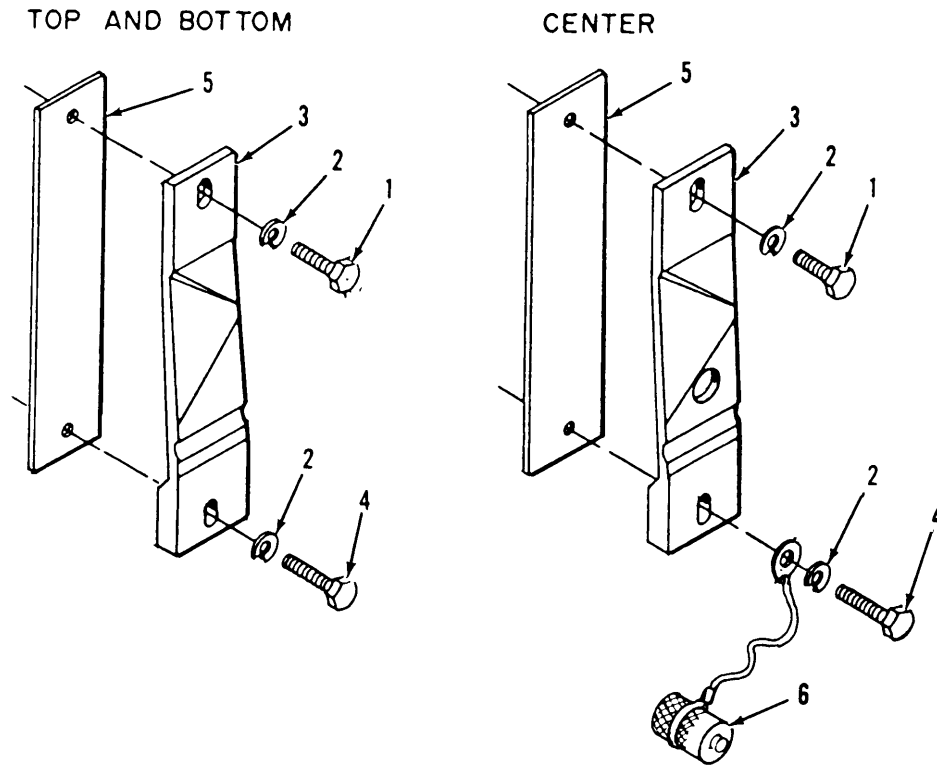

*Figure 3-24. Keeper Assembly Removal.*

---

**3-22. Door Brace Assembly.**

---

This task covers:

- a. Inspect
- b. Remove
- c. Disassemble
- d. Assemble
- e. Install

---

**INITIAL SETUP***Tools*

General Mechanic's Automotive Tool Kit

*Materials/Parts*Sealer (Item 28, Appendix D)  
Solid Film Lubricant (Item 22, Appendix D)

---

*a. Inspect.* (Figure 3-26)

- (1) Inspect for missing or damaged hardware,
- (2) Inspect for wear, dents, or other damage.
- (3) Inspect that the two hex-head screws (9) move freely.
- (4) Inspect for damaged door brace catch (5) and spring pin (4).

*b. Remove.* (Figure 3-25)

- (1) Remove and retain the ten phillips head screws (1) attaching the door brace (2) bracket (3) to door panel.
- (2) Remove and retain screw (4) attaching the pin and chain assembly (5) to door panel.
- (3) Remove and retain six hex head screws (6) attaching door stop angle (7) and shim (8) to shelter wall and remove door brace assembly (2) and shim (8).

*c. Disassemble.* (Figure 3-26)

- (1) Remove the cotter pin (1) and release the chain and pin assembly (2) and door stop bracket (3).
- (2) Punch out spring pin (4) and release the door brace catch (5).
- (3) Remove cotter pin (6) attaching castle nut (7) and remove castle nut (7), flat washer (8), and screw (9) to remove the lower brace assembly (10) from the brace assembly (11).
- (4) Remove cotter pin (6), screw (9), flat washer (8), and castle nut (7) attaching the brace assembly (11) to door stop angle (12).

---

3-22. Door Brace Assembly (cont).

---

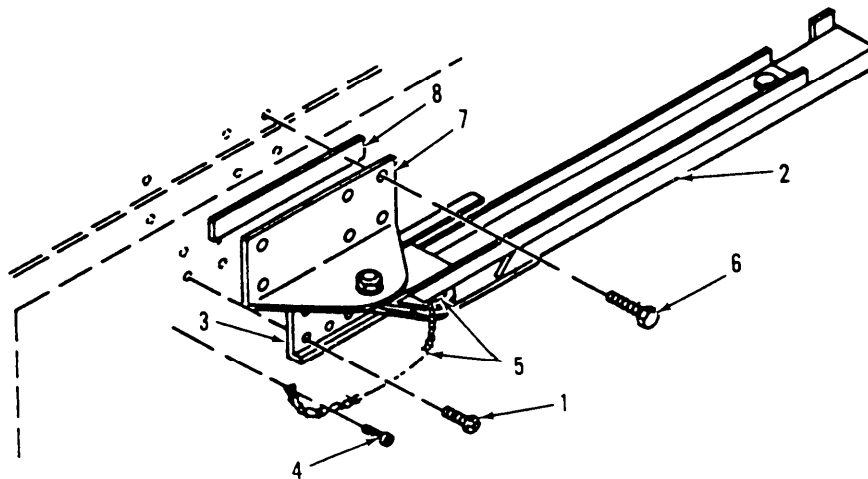

**Figure 3-25. Door Brace Assembly Removal.**

d. Assemble. (Figure 3-26)

- (1) Position the end of brace assembly (11) under door stop angle (12), align mounting holes and secure with a screw (9), flat washer (8), castle nut (7), and cotter pin (6).
- (2) Place lower brace assembly (10) under brace assembly (11), align mounting holes and secure with screw (9), flat washer (8), castle nut (7), and cotter pin (6).
- (3) Using the spring pin (4) attach the door stop catch (5) to lower brace assembly (10).
- (4) Place the free end of the lower brace (10) inside the door stop bracket (3) and secure with pin and chain assembly (2).
- (5) Secure pin and chain assembly (2) with cotter pin (1).

e. Install. (Figure 3-25)

- (1) Position shim (8) and doorstop angle (7) in place on shelter wall and secure with six hex head screws (6).
- (2) Place door brace bracket (3) on door, and secure to door panel with ten phillips head screws (1).
- (3) Secure chain end of pin and chain assembly (5) to door panel with screw (4).

---

3-22. Door Brace Assembly (cont).

---

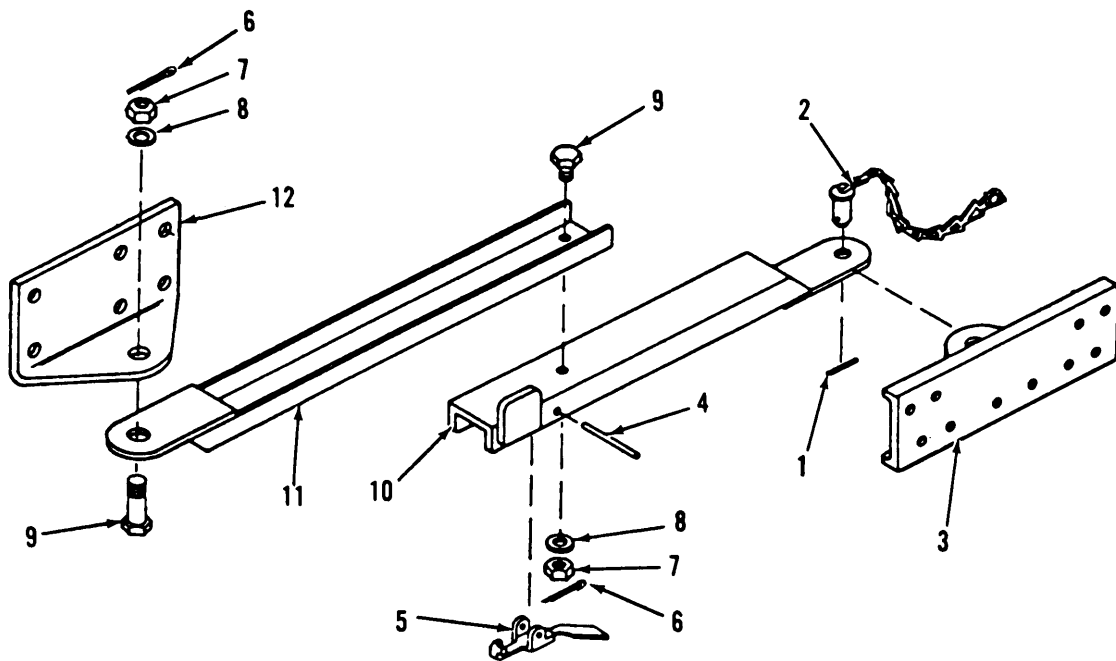

*Figure 3-26. Door Brace Assembly Maintenance*

**3-23. Recessed Step Pan Assembly.**

---

This task covers: a. Inspect  
b. Replace  
c. Repair

---

INITIAL SETUP

*Tools*

General Mechanic's Automotive Tool Kit  
Blind Riveter

*Materials/Parts*

Sealer (Item 28, Appendix D)  
Blind Rivets, Various

---

a. Inspect. (Figure 3-27)

- (1) Inspect for ease of positioning.
- (2) Inspect for cracks or other damage.

b. Replace. (Figure 3-27)

- (1) Pull step (1) out and down to operating position.
- (2) Remove two attaching locknuts (2) and remove step (1).
- (3) Remove three blind rivets (3) and seven blind rivets (4) attaching the recessed step pan (5) and remove from wall.
- (4) Position recessed step pan (5) in place on shelter wall and secure with seven blind rivets (4) and three blind rivets (3).
- (5) position step (1) in place and allow captivated bolts to enter the mounting holes of new step.
- (6) Using two locknuts (2) secure step (1) to recessed step pan (5).
- (7) place a bead of sealer around edges of recessed step pan assembly.

c. Repair. Repair of the recessed step assembly consists of replacement of the damaged or malfunctioning component.

3-23. Recessed Step Pan Assembly (cont).

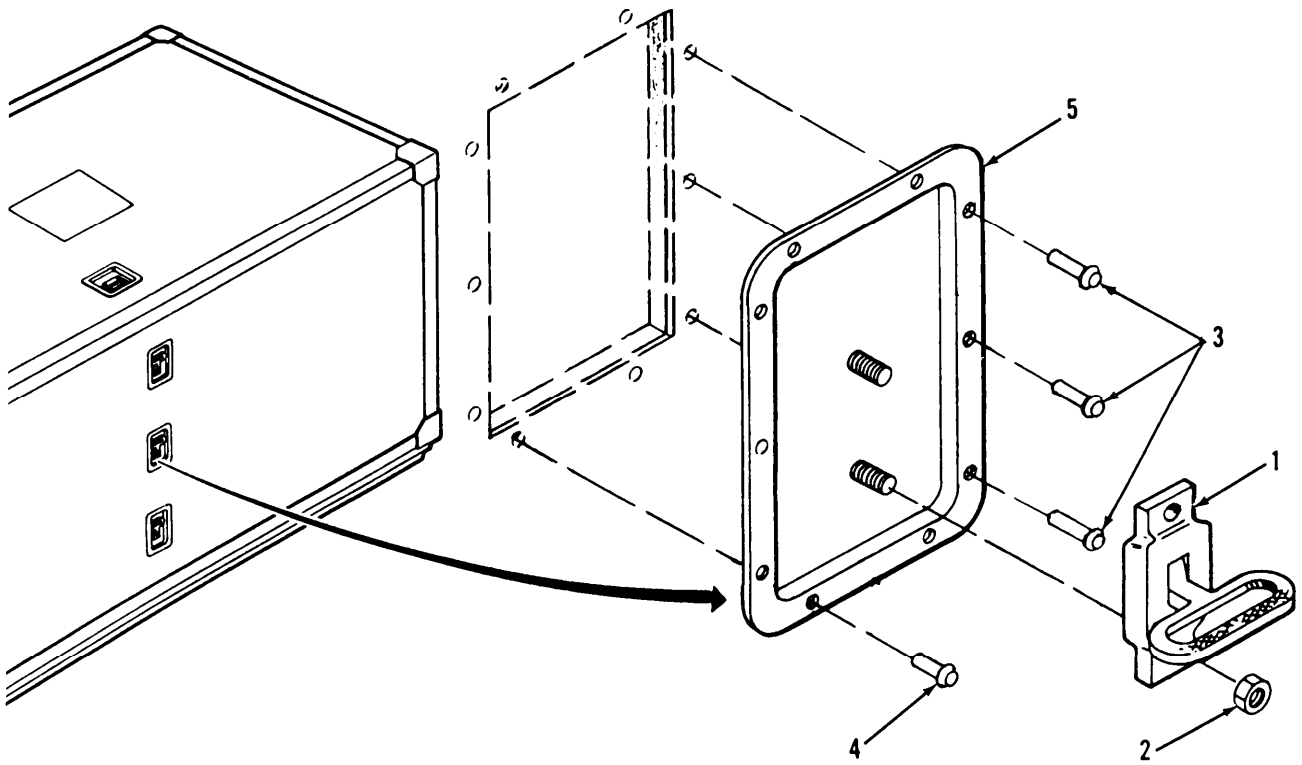

*Figure 3-27. Recessed Step Pan Assembly Replacement.*



---

**3-24. Towing Eye Assembly.**

---

This task covers: a. Inspect                      b. Replace                      c. Repair

---

**INITIAL SETUP**

*Tools*

General Mechanic's Automotive Tool Kit  
Spanner Wrench

*Materials/Parts*

Sealer (Item 28, Appendix D)

---

a. Inspect. (Figure 3-28)

- (1) Inspect for free movement and secure mounting.
- (2) Inspect for cracks or other external damage.

b. Replace.

- (1) remove the threaded ring collar (1) attaching the towing eye assembly (2) to the shelter using a spanner wrench.
- (2) Place the towing eye assembly (2) at the proper position on the shelter.
- (3) Attach the towing eye assembly threaded ring collar (1) to the shelter using a spanner wrench.
- (4) Add a continuous bead of sealer around periphery of threaded ring collar (1).

c. Repair. Repair of the towing eye assembly consists of replacement of a damaged or malfunctioning assembly.

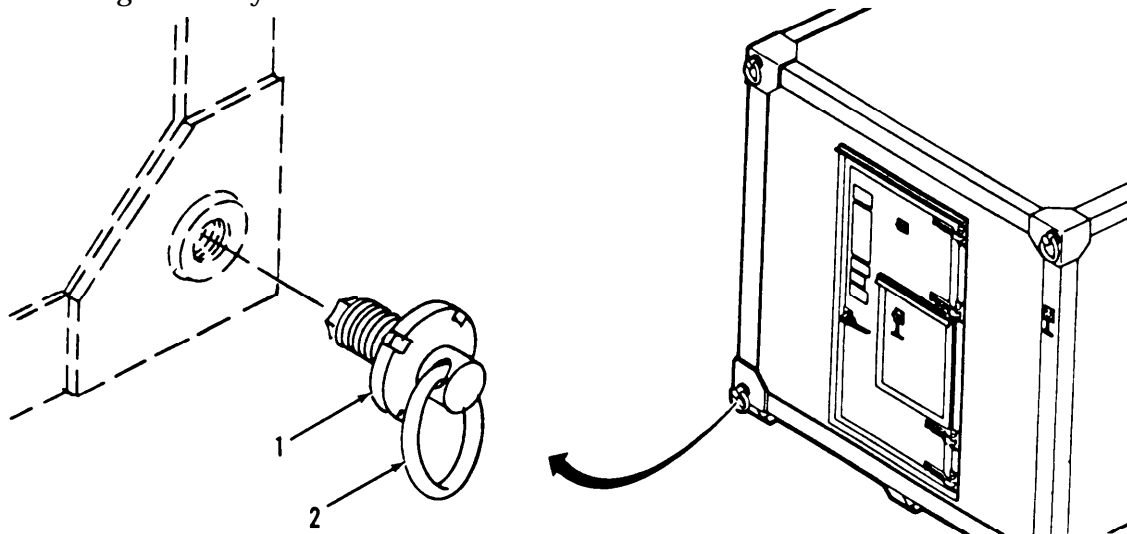

**Figure 3-28. Towing Eye Assembly Replacement**

**3-25. Lifting and Tiedown Eye Assembly.**

This task covers: a. Inspect                      b. Replace                      c. Repair

**INITIAL SETUP***Tools*

General Mechanic's Automotive Tool Kit  
Spanner Wrench

*Materials/Parts*

Sealer (Item 28, Appendix D)

a. *Inspect.* (Figure 3-29)

- (1) Inspect for free movement and secure mounting,
- (2) Inspect for cracks or other external damage.

b. *Replace.*

- (1) Remove the threaded ring collar (1) attaching the lifting and tiedown eye assembly (2) to the shelter using a spanner wrench.
- (2) Place the lifting and tiedown eye assembly (2) at the proper position on the shelter.
- (3) Attach the lifting and tiedown eye assembly threaded ring collar (1) to the shelter using a spanner wrench.
- (4) Add a continuous bead of sealer around periphery of threaded ring collar (1).

c. *Repair.* Repair of the lifting and tiedown eye assembly consists of replacement of a damaged or malfunctioning assembly.

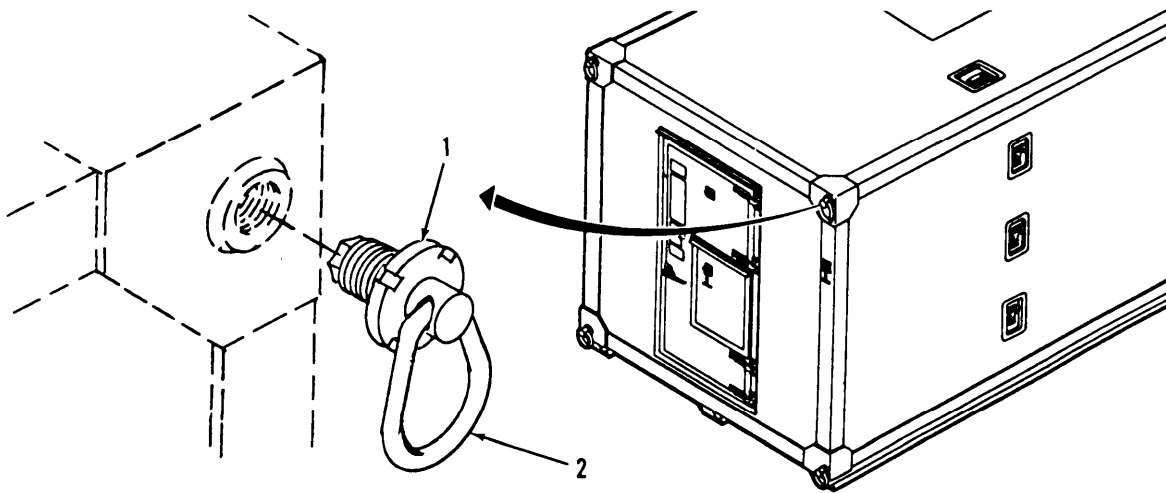

**Figure 3-29. Lifting and Tiedown Eye Assembly Replacement.**

**3-26. Skid Assembly.**

---

This task covers:

- a. Inspect
- b. Replace
- c. Repair

---

**INITIAL SETUP**

*Tools*

General Mechanic's Automotive Tool Kit  
Blind Riveter

*Personnel Required*

Two

*Materials/Parts*

Sealer (Item 28, Appendix D)  
Rivnuts, Various

---

- a. Inspect. (Figure 3-30)

**WARNING**

Prior to attempting to perform maintenance on the skids, ensure that shelter is supported properly to prevent injury to personnel.

- (1) Inspect for secure mounting and dents.
- (2) Inspect for damage to the shock mounts and foam filler.

**CAUTION**

The shelter should be raised and supports placed on the bottom of the front and rear panels between skids. The skids should be approximately one foot above the ground.

**NOTE**

Although the skids may be damaged with dents, they can be used again if the shock mounts and foam filler internally are replaced.

- b. Replace. (Figure 3-30)

- (1) Remove and retain six hex head bolts (1), twelve flat washers (2), and six nuts (3) attaching each skid assembly (4) to skid runner (5), and remove the skid assembly.
- (2) Remove any damaged shock mounts (6 and 7) and core (8, 9, and 10).

3-26. Skid Assembly (cont).

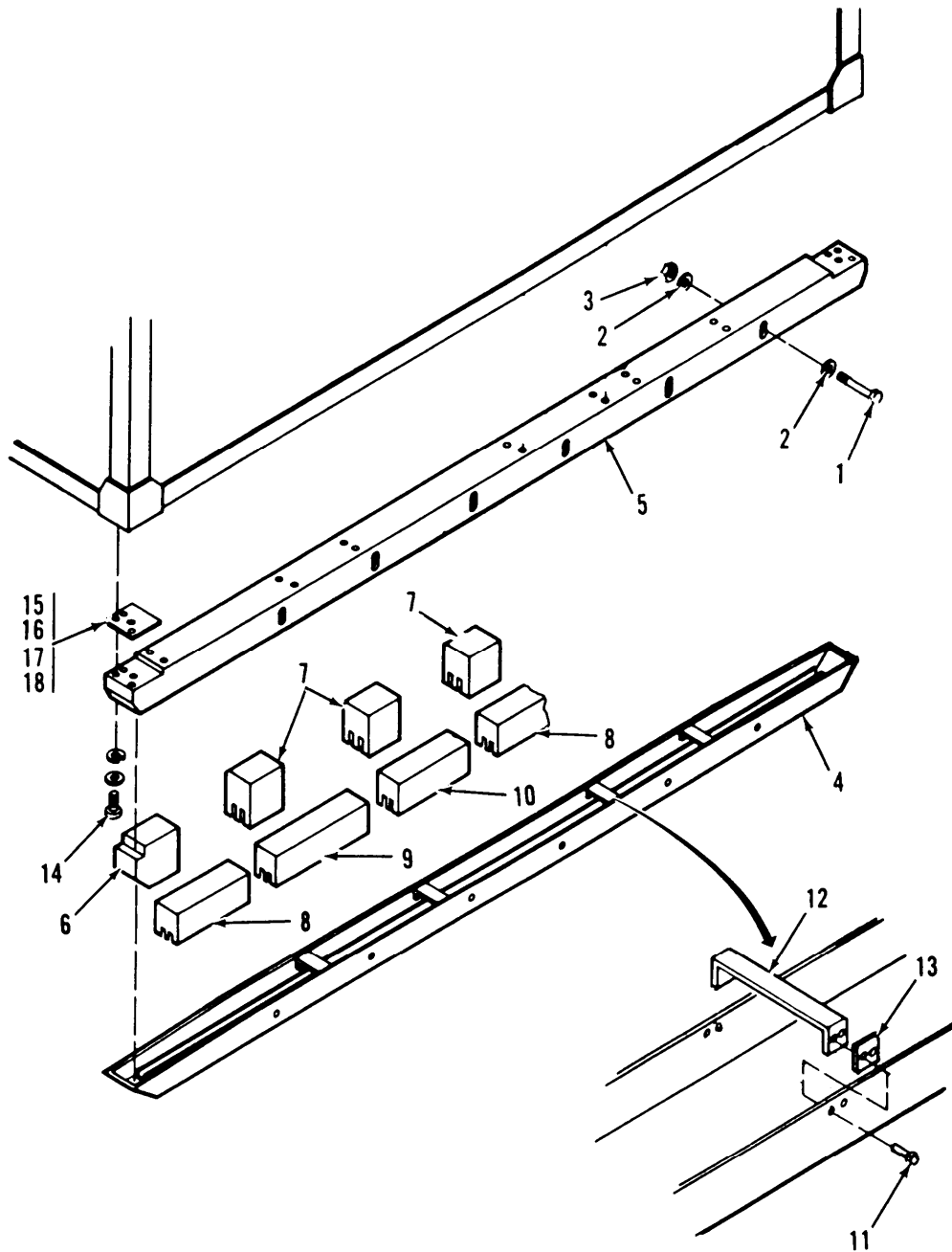

Figure 3-30. Skid Assembly Repair.

**3-26. Skid Assembly (cont).**

---

- (3) Remove four blind rivets (11) attaching each of the four channel brackets (12) and laminated shims (13) and remove brackets and shims.

**NOTE**

Replace the skid runner (5) only when it appears severely damaged and does not allow the proper installation of the skid.

- (4) Remove and retain 16 cap screws (14) attaching each skid runner (5) to shelter underside and remove runner (5) and shims (15, 16, 17, and 18).
- (5) Position shims (15, 16, 17, and 18) and each skid runner (5) in place and secure each to underside of shelter with 16 cap screws (14).
- (6) Place each of the four channel brackets (12) and laminated shims (13) inside skid (4), align mounting holes and secure to skid with four blind rivets (11).
- (7) Position new shock mounts (6 and 7) and core (8, 9, and 10) in place.
- (8) Position each skid assembly (4) inside the skid runner (5) and secure using six hex head bolts (1), twelve flat washers (2), and six nuts (3).

c. *Repair.* Repair of skid assembly consists of repair or replacement of a damaged skid or skid runner and replacement of damaged shock mounts and core material.

---

**3-27. Hold Down Assembly.**

---

This task covers:

- a. Inspect
- b. Replace
- c. Repair

---

**INITIAL SETUP***Tools*

General Mechanic's Automotive Tool Kit

---

a. *Inspect.* (Figure 3-31)

- (1) Inspect plate and eyebolt assembly (3) for wear and deformation.
- (2) Inspect cable assembly for missing or damaged hardware.
- (3) Inspect cable assembly hooks for proper operation.

b. *Replace.* (Figure 3-31)

- (1) To replace the ring assembly (1), open safety snap on attaching hook of each of the four cable assemblies (2) and remove hook from thimble of ring assembly.
- (2) Open safety snap on hook at opposite end of cable assembly (2) and remove hook from plate and eyebolt assembly (3).
- (3) Unscrew each of the two eyebolts (4) and remove from plate (5).
- (4) Push cable (6) out of plate (5), cut sleeve (7 or 8), and pull and remove cable from opposite direction.
- (5) Push new cable (6) through eyebolt mounting hole on top of plate (5).
- (6) Attach sleeve (7) at end of cable (6) and pull cable out until sleeve (7) stops inside plate (5).
- (7) Attach other end of cable (6) around eyebolt (4) and secure to eyebolt with sleeve (8).
- (8) Repeat steps 6 through 8 above with second cable and eyebolt.
- (9) Push safety hook of cable assembly (2) to attach eyebolt (4) of plate and eyebolt assembly (3).
- 10) Push safety hook of each cable assembly to attach each thimble of the ring assembly (1).

---

**3-27. Hold Down Assembly.**

---

*Repair.* Repair of hold down assembly consists of replacement of ring assembly (1), cable assembly (2), red/or damaged parts of the plate and eyebolt assembly (3), with a fully operation like item.

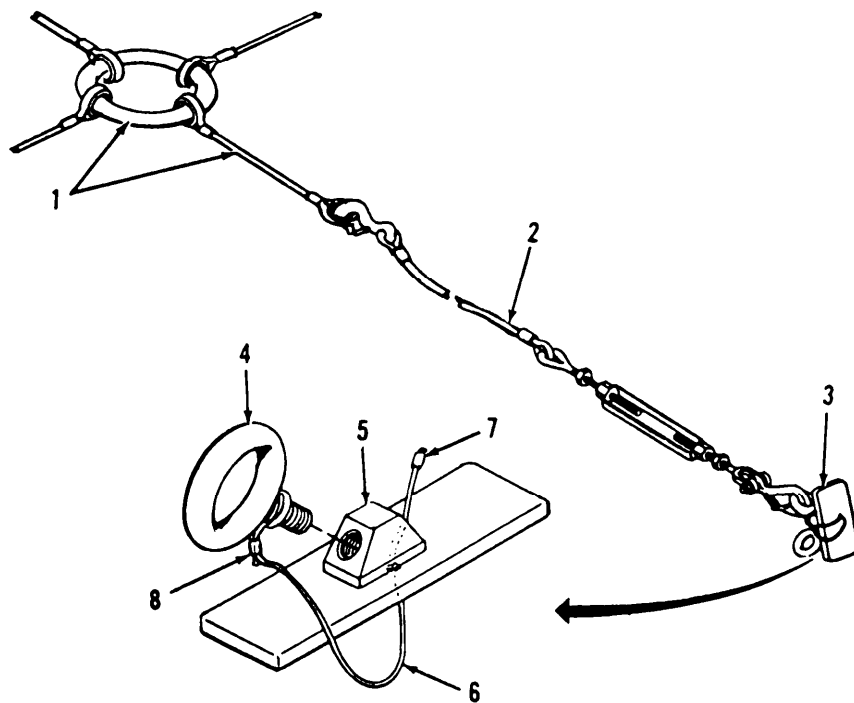

**Figure 3-31. Hold Down Assembly Repair.**

**3-28. Touch-up Painting.** When required, to prevent rust and corrosion, touch up small areas of damaged or chipped paint in accordance with TM 43-0139. If large areas need repainting, notify higher level of maintenance.

**Section VI. PREPARATION FOR SHIPMENT AND STORAGE**

Subject	Para	Page
General	3-29	3-61
Loading Shelter on a Truck or Rail Car. . . . .	3-30	3-61
Storing Shelter . . . . .	3-31	3-61

**3-29. General.** All items placed inside the shelter must be secured to prevent damage from shock or vibration during transport. The packaging, bracing, cushioning and tie-down method employed must be done so it will not allow damage to wall covering and equipment. Make sure the correct sling assembly is available and in good condition, the skids are in good condition and securely mounted to the shelter, and the drain plug is loosened for air or rail transport.

**3-30. Loading Shelter on a Truck or Rail Car.** The shelter with its payload is capable of being transported by commercial cargo vehicle or any standard 40-foot flatcar as used in the continental United States. During vehicular transport, the shelter should be secured as shown in Figure 3-32. During rail transport, the shelter shall be blocked and braced to avoid shifting on flatcar (Figure 3-33). The loaded shelter is capable of withstanding humping speeds of nine miles per hour with no permanent deformation.

**3-31. Storing Shelter.** Accumulation of moisture within the shelter resulting from temperature and humidity fluctuations can damage equipment. Minimize moisture accumulation by keeping shelter doors, louver covers, and drain holes open during indoor storage. During outdoor storage, keep doors and drain holes closed, but keep louver covers open.

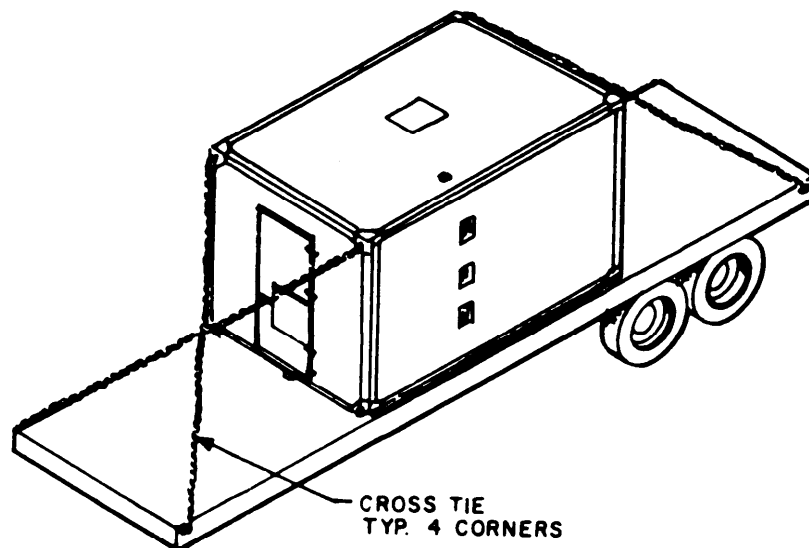

*Figure 3-32. Truck Tiedown.*



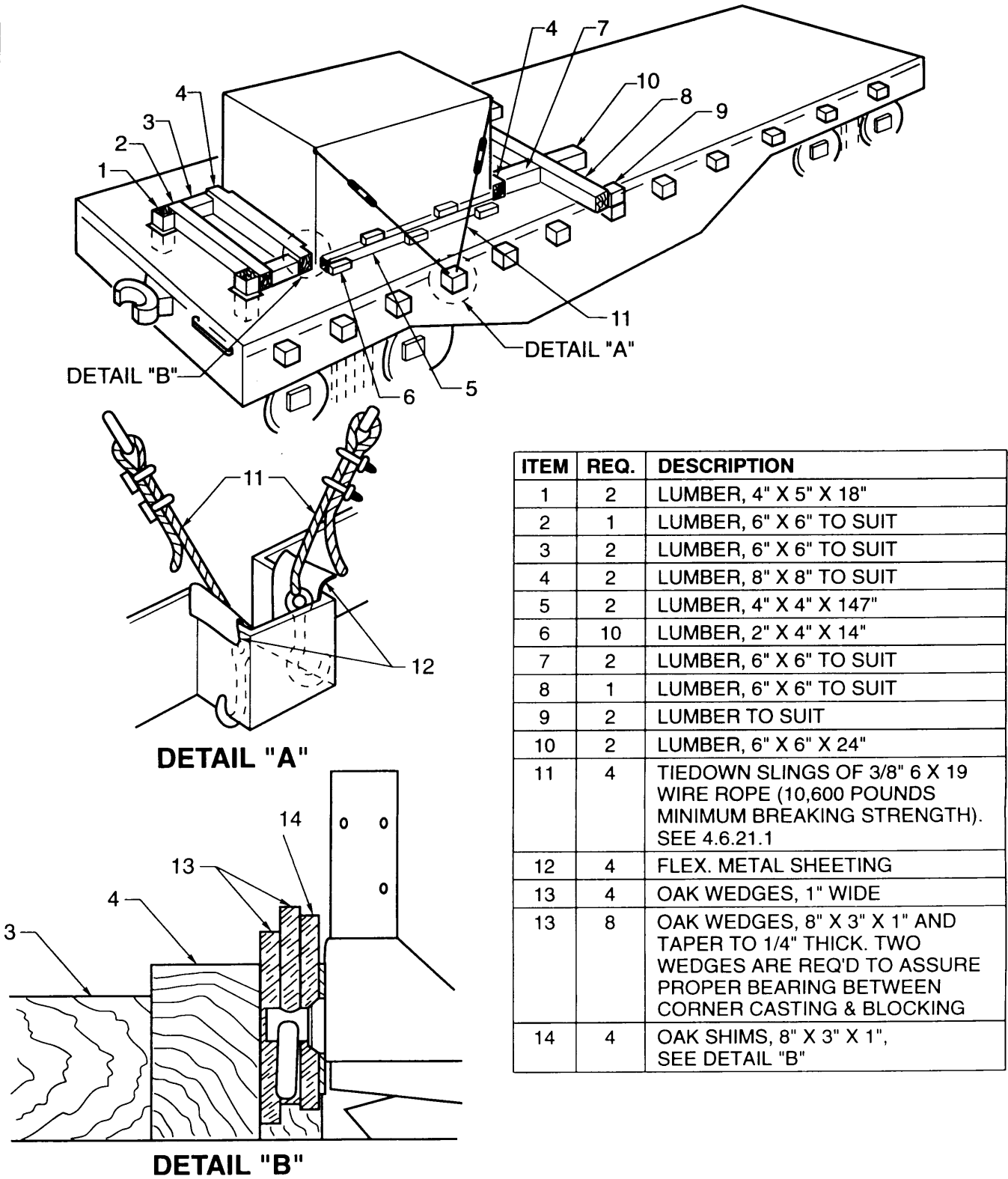

Figure 3-33. Rail Tiedown.

**CHAPTER 4**

**DIRECT SUPPORT MAINTENANCE INSTRUCTIONS**

Subject	Section	Page
Repair Parts, Special Tools, TMDE, and Support Equipment . . . . .	I	4-1
Troubleshooting . . . . .	II	4-1
Maintenance Instructions . . . . .	III	4-2

**Section I. REPAIR PARTS, SPECIAL TOOLS, TMDE, AND SUPPORT EQUIPMENT**

Subject	Para	Page
Common Tools . . . . .	4-1	4-1
Special Tools, TMDE, and Support Equipment . . . . .	4-2	4-1
Repair Parts . . . . .	4-3	4-1

**4-1. Common Tools.** A complete list of common tools and tool kits is given in Section III of Appendix B, Maintenance Allocation Chart.

**4-2. Special Tools, TMDE, and Support Equipment.** All special tools, TMDE, and support equipment are listed in Section III of Appendix B, Maintenance Allocation Chart, and in the Repair Parts and Special Tools List manual, TM 10-5411-207-24P, S-280C/G Shielded and S-280C/G Unshielded Electrical Equipment Shelters.

**4-3. Repair Parts.** Repair parts for direct support maintenance of the shelter are listed and illustrated in TM 10-5411-207-24P.

**Section II. TROUBLESHOOTING**

**4-4. Troubleshooting.** This section contains troubleshooting information for malfunctions which may develop in the shelter. Fault isolation is limited to those components which may be repaired or replaced at the direct support or general support level. Table 4-1 lists a common malfunction you may encounter during operation or maintenance of the shelter. The malfunction is followed by a list of tests or inspections and corrective actions. These tests or inspections and corrective actions should be performed in the order listed. This manual cannot list all malfunctions that may occur. If you encounter a malfunction that is not listed or cannot be corrected by the listed corrective actions, notify your supervisor.

Table 4-1. Troubleshooting.

---

**MALFUNCTION  
TEST OR INSPECTION  
CORRECTIVE ACTION**

---

1. WATER IS GETTING INTO SHELTER

- Step 1. Inspect shelter walls and ceiling for leaks.  
Patch any holes (paragraph 4-9, 4-10, or 4-11, as applicable).
- Step 2. Check that all exterior wall and ceiling patches are firmly mounted and bonded to shelter wall.  
Apply sealer around edge of patch, or replace patch (paragraph 4-9, 4-10, or 4-11, as applicable).
- Step 3. Check if lifting bracket assemblies or towing bracket assemblies have pulled away from shelter corners.
  - a. Apply sealer to gaps around bracket edges.
  - b. If replacement is required, notify higher level of maintenance.

---

**Section III. MAINTENANCE INSTRUCTIONS**

Subject	Para	Page
General . . . . .	4-5	4-2
Shelter Assembly Inspection . . . . .	4-6	4-2
Delamination Repair . . . . .	4-7	4-2
Repair of Small or Shallow Dent . . . . .	4-8	4-7
Repair of Large or Deep Dent . . . . .	4-9	4-9
Repair of Small Skin Puncture or Cut. . . . .	4-10	4-11
Repair of Large Skin Puncture or Cut . . . . .	4-11	4-13
Surface Preparation, Priming, and Painting . . . . .	4-12	4-16

4-5. **General.** The general maintenance information given for unit level maintenance also applies to direct support level maintenance. This information is contained in paragraph 3-8.

4-6. **Shelter Assembly Inspection.** The shelter assembly inspection performed by direct support level maintenance personnel consists of evaluating the damage to the shelter assembly previously identified and noted by unit level maintenance personnel, and determining the proper method of repair.

**CAUTION**

Any damage to structural members of the shelter will require maintenance beyond the capabilities of the direct support level maintenance facility.

If the inspection of the shelter assembly reveals damage to the structural members of the shelter, depot level maintenance personnel should be notified.

#### 4-7. Delamination Repair.

This task covers:

- a. Inspect
- b. Repair

##### INITIAL SETUP

##### *Tools*

General Mechanic's Automotive Tool Kit  
Riveter

##### *Materials/Parts*

Gloves (Item 1, Appendix D)  
Caulking Gun (Item 2, Appendix D)  
Caulking Cartridge (Item 3, Appendix D)  
Epoxy Resin (Items 4 & 5, Appendix D)  
Container, Unwaxed (Item 6, Appendix D)  
Roller Kit (Item 7, Appendix D)  
Tape, Masking (Item 8, Appendix D)  
Solvent, Toluene (Item 9, Appendix D)  
Cloth, Cotton (Item 10, Appendix D)  
Plywood (Item 11, Appendix D)  
Polyethylene Sheet (Item 12, Appendix D)  
Cloth, Emery (Items 13 & 14, Appendix D)  
Sandpaper (Item 15, Appendix D)  
Rivet, Countersunk (Item 16, Appendix D)  
Fiber Filled Polyester Resin (Item 17, Appendix D)

a. Inspect. The roof, floor, endwalls, and sidewalls are constructed of inner and outer aluminum panels which are attached to structural mounting members. The area between the inner and outer panels is filled with a polyurethane core bonded to the panels with an epoxy adhesive. Separation of aluminum panel and polyurethane core will cause a structural weakness in the area affected. To restore the overall strength of the shelter, large areas of delamination should be repaired as soon as possible. Delaminated areas of the shelter may be detected by movements of the aluminum panel similar to the movement of the bottom of an oil can when pressed. The presence of delaminated areas should produce a light, hollow sound and a bonded area a dull, solid sound. Sound will also change when tapping crosses panel mounting members. When it has been determined that a shelter panel area has been delaminated, repair as follows:

b. Repair. (Figure 4-1)

(1) Mark off the limits of delaminated area.

#### **CAUTION**

To ensure that opposite shelter wall skin is not punctured, make sure drill bit has a drill stop attached which will prohibit drill bit from exceeding a depth of 5/8 inch.

(2) Using Figure 4-1 as a visual guide, drill a 3/16 inch diameter hole in approximate center of delaminated area of affected panel only. This hole will be used to pump epoxy adhesive into delaminated area.

- 
- 
- (3) Drill 3/16 inch diameter pressure release holes no closer than 1/2 inch from edge of delaminated surface. Number of holes should be determined by size of delamination area. (Release holes should be approximately 2 inches apart.)

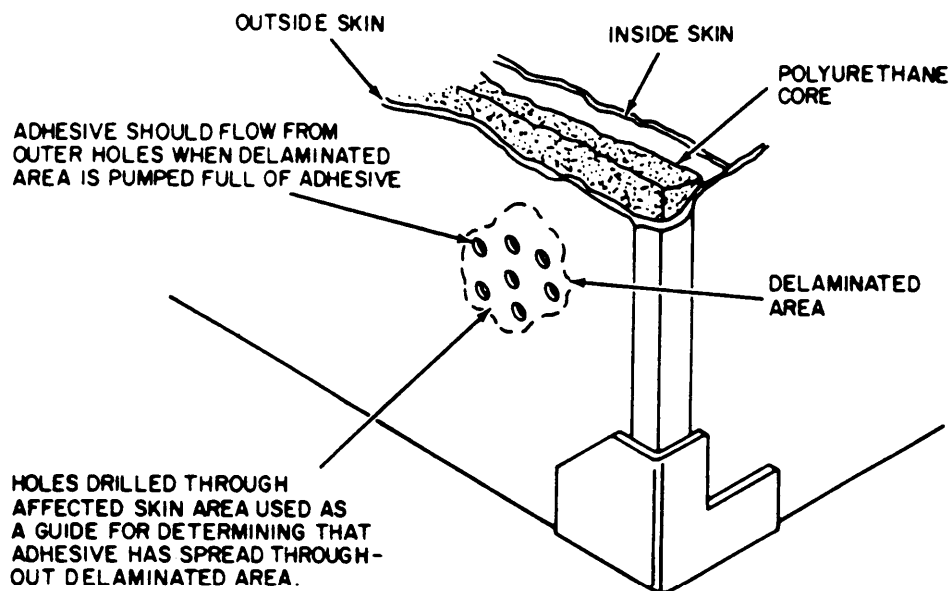

*Figure 4-1. Skin Panel Delamination Repair.*

**WARNING**

Gloves are to be worn when mixing and applying adhesive material due to possible skin irritation caused by adhesive coming into contact with the body skin surface.

**NOTE**

The Versamid material is extremely sensitive to moisture absorption. Therefore, make sure Versamid 140 container has lid firmly replaced after material has been removed from shipping or storage container. Both the Epic R1003 and the Versamid 140 materials have a shelf life of one year.

- (4) Using the outline of the marked delaminated area, mask off the surrounding area (approximately a width of 2 feet) with kraft wrapping paper or newspaper. Using unwaxed clean containers, mix thoroughly the Epic Resin and Versamid material as follows:
- (a) Mixing by weight -- Mix 15 ounces Epic R1003 to 5 ounces of Versamid 140.
  - (b) By volume -- 2 parts of Epic R1003 to 1 part of Versamid 140.

---

**4-7. Delamination Repair (cont).**

---

- (5) Utilizing a plastic cartridge (similar to a caulking cartridge) containing the mixed adhesive material, use a caulking gun to force mixed adhesive directly into the clearance holes in the guidelines as follows:

**CAUTION**

The following repair procedures must be accomplished within one hour of mixing adhesive. Do not attempt any repair unless temperature is between 60°F and 85°F.

- (a) Place nozzle of caulking gun in center hole of delaminated area and inject adhesive into space.
- (b) When space is filled with adhesive, remove caulking gun and using a roller, knead or roll lightly over adhesive filled panel surface, making certain adhesive fills all areas and that air entrapment and surplus adhesive is moved out through pressure release holes.
- (c) Seal center hole with masking tape.

**WARNING**

Alcohol solvents are flammable. Keep away from heat, sparks, and open flame. Keep containers closed when not used. Use only with adequate ventilation. Avoid prolonged breathing of vapors or repeated contact with skin.

- (d) Using a soft cloth lightly coated with alcohol solvent, remove excess adhesive from adhesive filled panel surface.
- (e) Cover adhesive filled panel with a sheet of polyethylene.
- (f) Place a 1/2 inch plywood sheet or equivalent against polyethylene sheet and apply an even surface pressure (bracing is sufficient) over repaired area for at least 24 hours.
- (g) After adhesive has been allowed to cure the required time, remove plywood and polyethylene sheet.
- (h) Sand the repaired area with sandpaper to remove excess cured adhesive,
- (i) Redrill a .190 diameter (#11 drill) by 5/8 inch deep hole at each of the holes previously drilled in paragraphs 4-7. b.(2) and 4-7.b.(3). Slightly countersink the drilled hole with a punch (.062 by 120 degrees) and install a 3/16 inch diameter countersunk pop rivet (AK66H).
- (j) Fill the hollow core portions of pop rivet and any surrounding uneven surface with body filler material, allowing to dry for 1 hour.

**4-7. Delamination Repair (cont).**

---

- (k) Grind repaired surface smooth and using emery cloth or sandpaper, remove any rough areas on surface and thoroughly clean repaired area with a soft cloth lightly coated with alcohol or toluene.
- (l) Prime and paint repaired panel surface and heads of pop rivets. (Refer to paragraph 4-12.)

---

**4-8. Repair of Small or Shallow Dent**

---

This task covers:           Repair

INITIAL SETUP

<i>Tools</i>	<i>Materials/Parts</i>
General Mechanic's Automotive Tool Kit	Cloth, Emery (Item 13, Appendix D) Sandpaper (Item 15, Appendix D) Fiber Filled Polyester Resin (Item 17, Appendix D)

---

**NOTE**

The following repair procedures are for a damaged area not exceeding 64-square inches.

Repair. (Figure 4-2)

- (1) Remove all paint or foreign matter from the dent (A, Figure 4-2), and an area approximately three inches wide around the dent, with emery cloth and cleaner.
- (2) Roughen the skin surface with coarse grit emery cloth. Be sure that the area is completely clean. Do not touch the area with hands or wipe with an oily cloth.
- (3) Fill the dent and smooth out evenly to a featheredge as shown in B, Figure 4-2, using any fiber filled polyester resin (body putty).
- (4) Allow the repair mix to set thoroughly in accordance with the manufacturer's recommendations.
- (5) Sand off excess material flush with the contour of the skin surface.
- (6) Prime and paint the repaired surface. (Refer to paragraph 4-12.)



---

4-8. Repair of Small or Shallow Dent (cont).

---

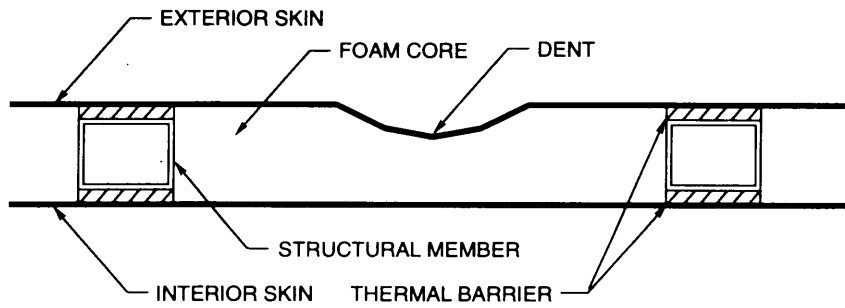

A - SMALL OR SHALLOW DENT IN SANDWICH CONSTRUCTION WITH ALUMINUM STRUCTURAL MEMBERS.

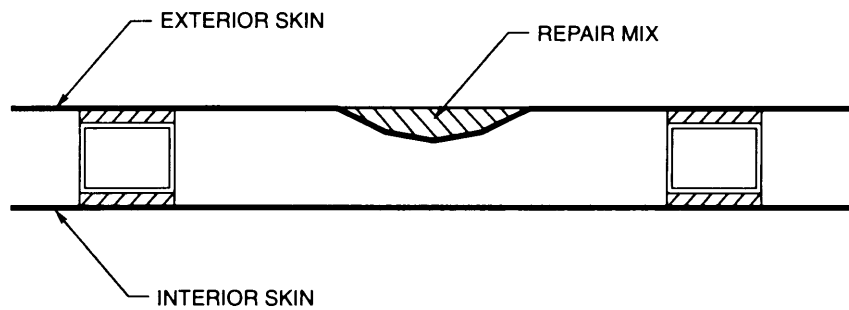

B - REPAIRED SMALL OR SHALLOW DENT.

*Figure 4-2. Shelter Wall Repair of Small Dent.*

---

#### 4-9. Repair of Large or Deep Dent.

---

This task covers:           Repair

##### INITIAL SETUP

###### *Tools*

General Mechanic's Automotive Tool Kit

###### *Materials/Parts*

Gloves (Item 1, Appendix D)  
 Caulking Gun (Item 2, Appendix D)  
 Caulking Cartridge (Item 3, Appendix D)  
 Epoxy Resin (Items 4 & 5, Appendix D)  
 Container, Unwaxed (Item 6, Appendix D)  
 Cloth, Emery (Item 13, Appendix D)  
 Sandpaper (Item 15, Appendix D)  
 Fiber Filled Polyester Resin (Item 17,  
 Appendix D)  
 Cloth, Fiberglass (Item 18, Appendix D)

---

#### NOTE

The following repair procedures are for a 64- to 100-square inch area, located between structural members. To determine that a large or deep dent is between structural members, tap area with a small screwdriver handle. A structural member is identified by a tight, drum-like sound as opposed to the soft sound of areas between members.

Extensive damage, such as denting or buckling of the exterior shelter skin (which displaces the opposite shelter skin) generally constitutes an unrepairable type damage. Follow the procedure in A, B, or C below to repair a large or deep dent involving only the exterior shelter skin.

##### Repair. (Figure 4-3)

- (1) Perform the procedures contained in paragraph 4-8, steps (1), (2), and (3) using Figure 4-3, A and B.
- (2) Cut a piece of fiberglass cloth that will cover the restored area and extend approximately two inches around the filled-in dent.
- (3) Apply a liberal coating of mixed adhesive (paragraph 4-7. b.(4)) over the filled-in dent extending approximately two inches around the dent.
- (4) Place the fiberglass cloth (C, Figure 4-3) over the coating of mixed adhesive and press lightly.

**4-9. Repair of Large or Deep Dent (cont).**

- (5) Apply a liberal coating of mixed adhesive over the fiberglass cloth; work from the center of the fiberglass cloth to the extreme edges. Be careful that all edges of the fiberglass cloth are thoroughly saturated.
- (6) Allow the mixed adhesive to set thoroughly and sand off excess.
- (7) Prime and paint the required surface. (Refer to paragraph 4-12.)

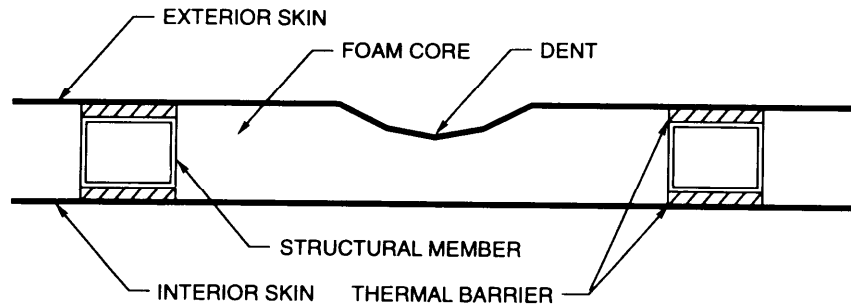

**A - LARGE OR DEEP DENT IN SANDWICH CONSTRUCTION BETWEEN STRUCTURAL MEMBERS.**

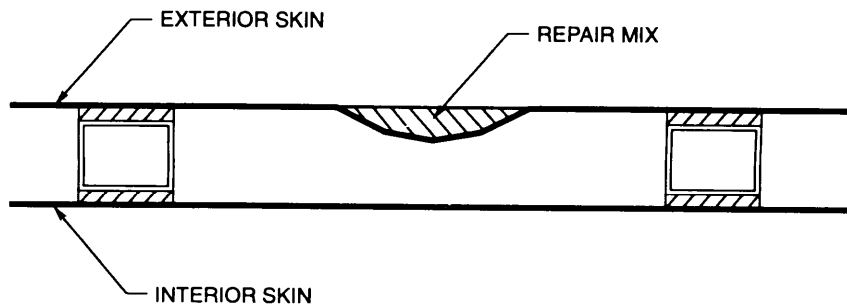

**B - LARGE OR DEEP DENT FILLED IN WITH REPAIR MIX.**

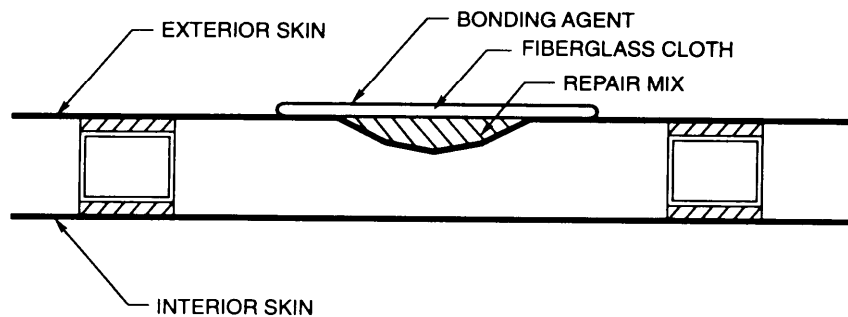

**C - REPAIRED LARGE OR DEEP DENT.**

*Figure 4-3. Shelter Wall Repair of Large Dent,*

---

#### 4-10. Repair of Small Skin Puncture or Cut.

---

This task covers:           Repair

##### INITIAL SETUP

<i>Tools</i>	<i>Materials/Parts</i>
General Mechanic's Automotive Tool Kit Riveter	Gloves (Item 1, Appendix D) Caulking Gun (Item 2, Appendix D) Caulking Cartridge (Item 3, Appendix D) Epoxy Resin (Items 4 & 5, Appendix D) Container, Unwaxed (Item 6, Appendix D) Cloth, Cotton (Item 10, Appendix D) Cloth, Emery (Item 13, Appendix D) Solvent, Toluene (Item 9, Appendix D) Aluminum (Item 19, Appendix D) Rivet Countersunk (Item 16, Appendix D)

---

##### Repair. (Figure 4-4)

- (1) Select an aluminum skin patch that overlaps the puncture or cut by one inch in all directions.
- (2) Position the aluminum skin patch over the puncture and lightly scribe the area of the patch on the shelter skin.
- (3) Remove all paint or foreign matter from the puncture area and an area approximately one inch around the scribed mark using an emery cloth and toluene solvent.
- (4) With the aluminum patch over the puncture area, drill holes for 3/16 inch pop rivets (#11 drill) around the perimeter of the patch, 1/2 inch from the edge of the patch and on one inch centers.
- (5) Roughen the skin surface with coarse grit emery cloth. Be sure that the area is completely clean. Do not touch the area with the hands or wipe with an oily cloth.
- (6) Fill the puncture with a fiber filled polyester resin. Then, smooth out evenly to a featheredge as shown in Figure 4-4, B.
- (7) Allow the resin to set thoroughly. Then, sand off excess flush with the contour of the skin surface.
- (8) Use the aluminum skin patch as a template to mark pop rivet holes in the skin of the shelter, and drill #30 holes in the skin of the shelter.

**4-10. Repair of Small Skin Puncture or Cut (cont).**

- (9) Coat the back surface of the aluminum skin patch and the shelter skin within the scribe lines with mixed adhesive (paragraph 4-7. b.(4)).
- (10) Position the aluminum skin patch over the repaired area.
- (11) Dip the pop rivets in the mixed adhesive and use the riveting tool for pop rivets to secure the aluminum skin patch to the shelter skin (C, Figure 4-4).
- (12) With a cloth, saturated in toluene solvent, squeeze out and remove immediately any excess mixed adhesive.
- (13) Prime and paint the repaired surface. (Refer to paragraph 4-12.)

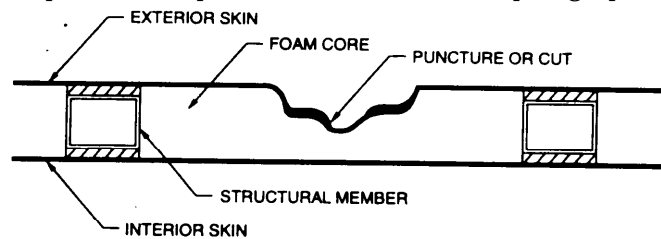

**A - SMALL SINGLE SKIN PUNCTURE OR CUT IN SANDWICH CONSTRUCTION.**

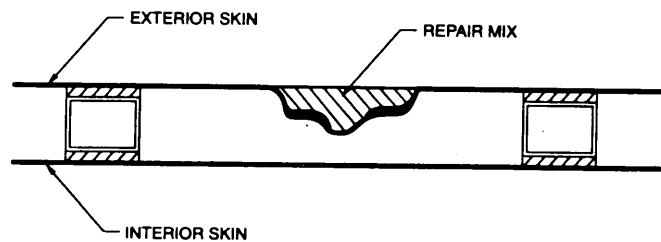

**B - SMALL SINGLE SKIN PUNCTURE OR CUT FILLED IN WITH REPAIR MIX.**

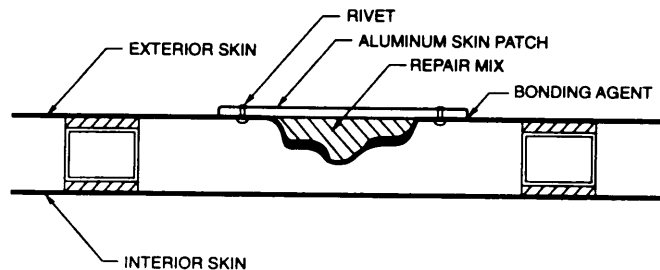

**C - REPAIRED SMALL SINGLE SKIN PUNCTURE OR CUT.**

**NOTE:**  
A GOOD QUALITY COMMERCIAL GLASS FILLED EPOXY RESIN MAY BE USED IN PLACE OF REPAIR MIX.

**Figure 4-4. Shelter Wall Repair of Small Skin Puncture.**

#### 4-11 Repair of Large Single Skin Puncture or Cut.

This task covers: Repair

##### INITIAL SETUP

##### *Tools*

General Mechanic's Automotive Tool Kit  
Riveter

##### *Materials/Parts*

Gloves (Item 1, Appendix D)  
Caulking Gun (Item 2, Appendix D)  
Caulking Cartridge (Item 3, Appendix D)  
Epoxy Resin (Items 4 & 5, Appendix D)  
Container, Unwaxed (Item 6, Appendix D)  
Polyethylene Sheet (Item 20, Appendix D)  
Cloth, Cotton (Item 10, Appendix D)  
Cloth, Emery (Item 13, Appendix D)  
Solvent, Toluene (Item 9, Appendix D)  
Aluminum (Item 19, Appendix D)  
Rivet, Countersunk (Item 16, Appendix D)  
Core Material (Item 31, Appendix D)

#### NOTE

The following repair procedures are for damaged skin between structural members. If the puncture or cut did not seriously damage the foam core, follow the procedures in paragraph 4-9. If the puncture or cut damaged the foam core, follow the procedures below using block insulation or a cutout.

##### Repair. (Figure 4-5)

- (1) Select an aluminum skin patch that overlaps the puncture or cut by one inch in all directions.
- (2) Use the aluminum skin patch as a template positioned over the puncture or cut, and lightly scribe the area of the aluminum skin patch on the skin of the shelter.
- (3) Use a saw to cut and remove the punctured or cut skin area approximately one inch within the scribed mark (A and B, Figure 4-5). While cutting, take care not to cause additional damage to wall or interior skin.
- (4) Cut the foam core evenly along the edges where the skin is removed and remove the damaged foam core (B, Figure 4-5), maintaining perpendicular and straight edges.
- (5) Select a piece of block insulation or a cutout of the same type sandwich construction (C, Figure 4-5).

**4-11. Repair of Large Single Skin Puncture or Cut (cont).**

---

- (6) Size the block insulation or cutout to fit the opening where the skin and foam were removed. If a cutout is used, remove the aluminum skin from one side of the cutout.
- (7) Remove all paint or foreign matter from the overlap area on the skin of the shelter and an area approximately one inch around the scribed mark using emery cloth and cleaner. If the cutout is used, remove all paint or foreign matter from the aluminum skin of the cutout.
- (8) Roughen the skin surface with coarse grit emery cloth. If a cutout is used, roughen the surface of the aluminum skin.
- (9) Coat the interior of the opening where the skin and foam core were removed with mixed adhesive (paragraph 4-7.b.(4)).
- (10) Insert the block insulation or cutout into the opening where the skin and foam core were removed (D, Figure 4-5).
- (11) With the aluminum patch over the puncture area, drill #30 holes, around the perimeter of the patch, 1/2 inch from edge of patch and on one inch centers.
- (12) Coat the exposed block insulation or cutout and the overlap area with mixed adhesive.
- (13) Dip the pop rivets in the mixed adhesive and use the riveting tool for pop rivets to install the aluminum skin patch as shown (E, Figure 4-5).
- (14) Smooth and taper mixed adhesive (squeezed out during the riveting process) along the edges of the aluminum skin patch and immediately remove excess mixed adhesive with cloth saturated in toluene solvent.
- (15) Prime and paint the repaired surface. (Refer to paragraph 4-12.)
- (16) Inspect the repaired area to ensure that rivets and paint were applied correctly.

4-11. Repair of Large Single Skin Puncture or Cut (cont).

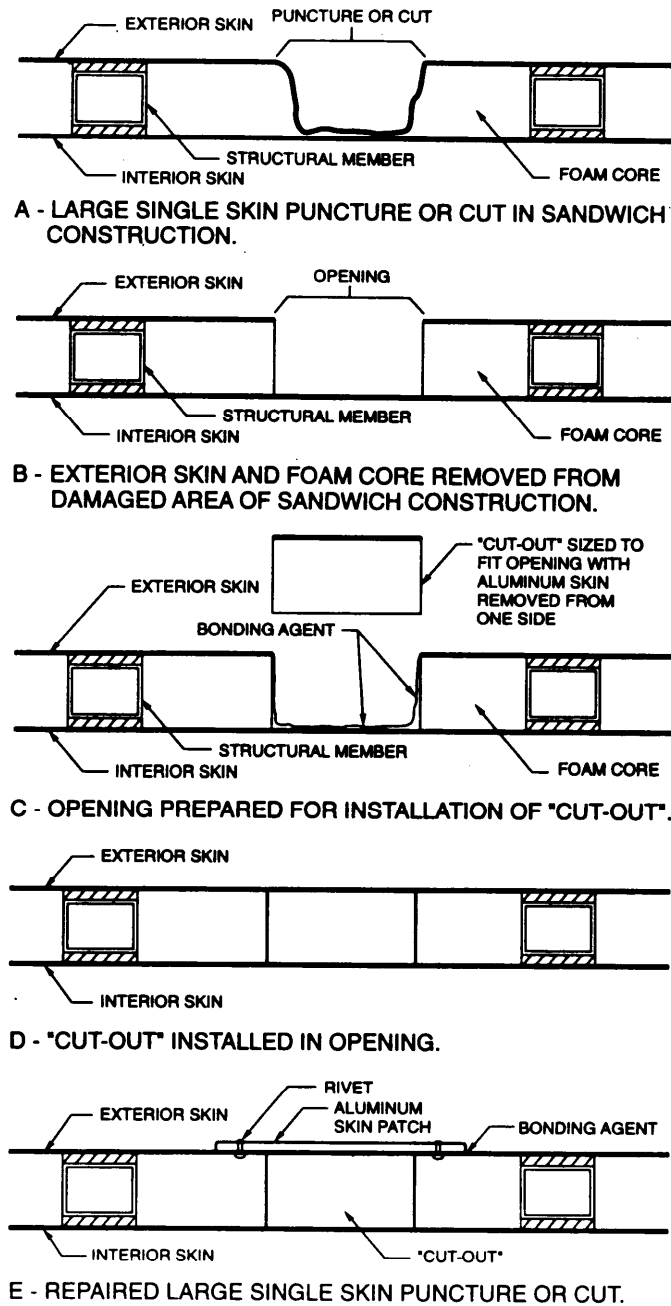

Figure 4-5. Shelter Wall Repair of Large Skin Puncture or Cut.



**4-12. Surface Preparation, Priming, and Painting.** All bare metal shall be painted to prevent corrosion. Touch up small dents and chips. Repaired sections of panels must be prepared with a corrosion-protection primer before painting. Do not attempt to repaint large areas such as complete exterior, interior, or ceiling. Detailed priming and painting instructions can be found in TM 43-0139.

**CHAPTER 5**

**GENERAL SUPPORT MAINTENANCE INSTRUCTIONS**

Subject	Section	Page
Repair Parts, Special Tools, TMDE, and Support Equipment . . . . .	I	5-1
Maintenance Instructions . . . . .	II	5-1

**Section I. REPAIR PARTS, SPECIAL TOOLS, TMDE, AND SUPPORT EQUIPMENT**

Subject	Para	Page
Common Tools . . . . .	5-1	5-1
Special Tools, TMDE, and Support Equipment. . . . .	5-2	5-1
Repair Parts . . . . .	5-3	5-1

**5-1. Common Tools.** A complete list of common tools and tool kits is given in Section III of Appendix B, Maintenance Allocation Chart.

**5-2. Special Tools, TMDE, and Support Equipment.** All special tools, TMDE, and support equipment are listed in Section III of Appendix B, Maintenance Allocation Chart, and in the Repair Parts and Special Tools List manual, TM 10-5411-207-24P, S-280C/G Shielded and S-280C/G Unshielded Electrical Equipment Shelters.

**5-3. Repair Parts.** There are no repair parts for general support level maintenance.

**Section II. MAINTENANCE INSTRUCTIONS**

Subject	Para	Page
General . . . . .	5-4	5-1

**5-4. General.** There are no maintenance instructions for general support level maintenance. The MAC does not identify any maintenance to be performed at this level.

**APPENDIX A**

**REFERENCES**

**A-1. Scope.** This appendix lists all forms, military specifications, technical manuals and miscellaneous publications referenced in this manual.

**A-2. Forms and Records.**

Recommended Changes to Publications and Blank Forms . . . . .	DA Form 2028
Equipment Inspection and Maintenance Worksheet . . . . .	DA Form 2404
Consolidated Index of Army Publications and Blank Forms . . . . .	DA Pam 25-30
The Army Maintenance Management System (TAMMS) . . . . .	DA Pam 738-750
Quality Deficiency Report (QDR) . . . . .	SF 368
Transportation Discrepancy Report (TDR) . . . . .	SF 361

**A-3. Military Specifications.**

Cloth, Cheesecloth, Cotton, Bleached and Unbleached . . . . .	CCC-C-440
Coating, Epoxy, Polyamide . . . . .	MIL-C-22750
Coating, Aliphatic, Polyurethane, Chemical Agent Resisting . . . . .	MIL-C-46168
Lubricant, Solid Film, Air Drying, Corrosion Inhibiting . . . . .	MIL-L-23398
Marking of Electronic Items . . . . .	MIL-M-13231
Sealing Compound, Temperature-Resistant, Integral Fuel Tank and Fuel Cell Cavities, High Adhesion Sealant . . . . .	MIL-S-8802
Silicone Compound, NATO Code Number S-736 . . . . .	MIL-S-8660C
Aluminum Alloy, Bar, Rod, Shapes, Tube and Wire, Extruded . . . . .	QQ-A-200/8
Aluminum Alloy 6061, Plate and Sheet . . . . .	QQ-A-250/11
Thinner, Synthetic Resin, Enamels . . . . .	TT-T-306
Toluene, Technical Grade . . . . .	TT-T-548

**A-4. Technical Manuals and Bulletins.**

Unit, Direct Support and General Support Maintenance Repair Parts and Special Tools List for Shelter, Electrical Equipment S-280C/G (Shielded) and S-280C/G (Unshielded) . . . . .	TM 10-5411-207-24P
Warranty Program for Electrical Equipment Shelters (Gichner) . . . . .	TB 10-5411-207-14
Warranty Program for Electrical Equipment Shelters (Ramim) . . . . .	TB 10-5411-207-24-1
Painting Instructions for Field Use . . . . .	TM 43-0139
Destruction of Army Materiel to Prevent Enemy Use . . . . .	TM 750-244-3
Artificial Respiration (First Aid Procedures) . . . . .	FM 21-11

## APPENDIX B

### MAINTENANCE ALLOCATION CHART

#### Section I. INTRODUCTION

##### **B-1. General.**

a. This section provides a general explanation of all maintenance and repair functions authorized at various maintenance levels.

b. The Maintenance Allocation Chart (MAC) in Section II designates overall responsibility for the performance of maintenance functions on the identified end item or component. The implementation of the maintenance functions upon the end item or component will be consistent with the assigned maintenance functions.

c. Section III lists the special tools and test equipment required for each maintenance function as referenced from Section II.

d. Section IV contains supplemental instructions and explanatory notes for a particular maintenance function.

##### **B-2. Maintenance Functions.**

a. Inspect. To determine the serviceability of an item by comparing its physical, mechanical, and/or electrical characteristics with established standards through examination.

b. Test. To verify serviceability and detect incipient failure by measuring the mechanical or electrical characteristics of an item and comparing those characteristics with prescribed standards.

c. Service. Operations required periodically to keep an item in proper operating condition, i.e., to clean (decontaminate), to preserve, to drain, to paint, or to replenish fuel, lubricants, hydraulic fluids, or compressed air supplies.

d. Adjust. To maintain, within prescribed limits, by bringing into proper or exact position, or by setting the operating characteristics to specified parameters.

e. Alin. To adjust specified variable elements of an item to bring about optimum or desired performance.

f. Calibrate. To determine and cause corrections to be made or to be adjusted on instruments or test measuring and diagnostic equipment used in precision measurement. Consists of comparisons of two instruments, one of which is a certified standard of known accuracy, to detect and adjust any discrepancy in the accuracy of the instrument being compared.

g. Install. The act of emplacing, seating, or fixing into position an item, part, or module (component or assembly) in a manner to allow the proper functioning of an equipment or system.

**B-2. Maintenance Functions (cont).**

*h. Replace.* The act of substituting a serviceable like type part, subassembly, or module (component or assembly) for an unserviceable counterpart.

*i. Repair.* The application of maintenance services or other maintenance actions to restore serviceability to an item by correcting specific damage, fault, malfunction, or failure in a part, subassembly, module (component or assembly), end item, or system.

*j. Overhaul.* That maintenance effort (services/actions) necessary to restore an item to a completely serviceable/operational condition as prescribed by maintenance standards (i.e., DMWR) in appropriate technical publications. Overhaul is normally the highest degree of maintenance performed by the Army. Overhaul does not normally return an item to like new condition.

*k. Rebuild.* Consists of those services/actions necessary for the restoration of unserviceable equipment to a like new condition in accordance with original manufacturing standards. Rebuild is the highest degree of material maintenance applied to Army equipment. The rebuild operation includes the act of returning to zero those age measurements (hours/miles, etc.) considered in classifying Army equipments/components.

**B-3. Explanation of Columns in the MAC, Section II.**

*a. Column 1, Group Number.* Column 1 lists group numbers, the purpose of which is to identify components, assemblies, subassemblies, and modules with the next higher assembly.

*b. Column 2, Component/Assembly.* Column 2 contains the names of components, assemblies, subassemblies, and modules for which maintenance is authorized.

*Column 3, Maintenance Functions.* Column 3 lists the functions to be performed on the item listed in column 2. (For detailed explanation of these functions, see paragraph B-2.)

*d. Column 4, Maintenance Level.* Column 4 specifies, by the listing of a "work time" figure in the appropriate sub-column(s), the lowest level of maintenance authorized to perform the function listed in column 3. This figure represents the active time required to perform the maintenance function at the indicated level of maintenance. If the number or complexity of the tasks within the listed maintenance function vary at different maintenance levels, appropriate "work time" figures will be shown for each level. The number of man-hours specified by the "work time" figure represents the average time required to restore an item (assembly, subassembly, component, module, end item, or system) to a serviceable condition under typical field operating conditions. This time includes preparation time, troubleshooting time, and quality assurance/quality control time in addition to the time required to perform the specific tasks identified for the maintenance functions authorized in the maintenance allocation chart. The symbol designations for the various maintenance levels are as follows:

Code	Explanation
C . . . . .	Operator or crew
O . . . . .	Unit maintenance
F . . . . .	Direct support maintenance
H . . . . .	General support

e. Column 5, Tools and Equipment. Column 5 specifies, by code, those common tool sets (not individual tools) and special tools, TMDE, and support equipment required to perform the designated function.

f. Column 6, Remarks. This column shall, when applicable, contain a letter code, in alphabetic order, which shall be keyed to the remarks contained in section IV.

**B-4. Explanation of Columns in Tools and Test Equipment Requirements, Section III.**

a. Column 1, Reference Code. The tool and TMDE reference code correlates with a code used in the MAC, Section II, Column 5.

b. Column 2, Maintenance Level. The lowest level of maintenance authorized to use the tool or test equipment.

c. Column 3, Nomenclature. Name or item identification of the tool or test equipment.

d. Column 4, National Stock Number. The National stock number of the tool or TMDE.

e. Column 5, Tool Part Number. The manufacturer's part number.

**B-5. Explanation of Columns in Remarks, Section IV.**

a. Reference Code. The code recorded in column 6, Section II.

Remarks. This column lists information pertinent to the maintenance function being performed as indicated in the MAC, Section II.

**Section II. MAINTENANCE ALLOCATION CHART FOR  
SHELTER ELECTRICAL EQUIPMENT  
S-280C/G UNSHIELDED AND S-280C/G SHIELDED**

(1) GROUP NUMBER	(2) COMPONENT/ASSEMBLY	(3) MAINTENANCE FUNCTION	(4) MAINTENANCE CATEGORY				(5) TOOLS AND EQPT.	(6) REMARKS
			C	O	F	H		
00	Shelter Assembly SM-D-947080 (Unshielded) SC-C-595083 (Shielded)	Inspect Repair	0.2	0.2 0.7	0.2 5.0		1-6	B,C,D
01	Door Assembly SM-D-947116	Inspect Adjust Replace Repair	0.3	2.4 4.0 3.0			2 2 2 2-6	B B,C,D
0101	Panel Assembly, Emergency Exit SM-D-450462	Inspect Replace Repair	0.1	0.7 1.7			2-6	B B,C,D
02	Door Latch Assembly SC-D-200140	Inspect Service Replace Repair	0.1	0.3 1.0 1.4			2 2	A B B
03	Keeper Assembly SC-C-200154	Inspect Replace	0.1	0.2			2-6	A,B
04	Door Brace Assembly SC-D-595548	Inspect Service Replace Repair	0.2	0.1 1.8 0.7			2 2-6	A B B
05	Pan Assembly Recessed Step SM-D-555567	Inspect Replace Repair	0.1	0.1 0.7 0.2			2-6 2-6	B B
06	Towing Eye Assembly SM-C-947147	Inspect Replace Repair	0.1	0.2 1.0			2,7 2,7	E E
07	Lifting and Tiedown Eye Assembly SM-C-947176	Inspect Replace Repair	0.1	0.2 1.0			2 2	E E
08	Skid Assembly SM-D-947238	Inspect Replace Repair	0.2	3.7 1.0			2-6	B B
09	Hold Down Assembly SC-D-36423	Inspect Repair	0.1	0.2			2	B

**Section III. TOOL AND TEST EQUIPMENT REQUIREMENTS  
SHELTER ELECTRICAL EQUIPMENT S-280C/G**

TOOL AND TEST EQUIPMENT REQUIREMENTS				
TOOL OR TEST EQUIPMENT REFERENCE CODE	MAINTENANCE CATEGORY	NOMENCLATURE	NATIONAL/NATO STOCK NUMBER	TOOL NUMBER
1	O	Tool Kit	5180-00-610-8177	TK-105/G
2	F, O	Tool Kit, Automotive	5180-00-177-7033	SC5180-90-CL-N26
3	F	Tool Kit	5180-973-4369	TK-144/G
4	O	Riveter, Blind Hand	5120-00-224-9298	C-6006-32
5	O	Drill, Electric	5130-00-889-8994	WD00661
6	O	Drill, Twist	5133-00-189-9256	MS15444-82
7	O	Spanner Wrench, Two Pin, 1.875	5120-00-613-7912	GGG-W-665B, Type III, Class 1
8	O	Rivnut Installation Tool		C-722

**Section IV. REMARKS**

Reference Code	Remarks
A	Lubricate hinges and door mechanism, replace door filter, touchup paint
B	Replace damaged part
C	Skin damage
D	Skin damage, thread fastened parts, gaskets
E	Replace entire assembly. No repair parts functional group code assigned



## APPENDIX C

## COMPONENTS OF END ITEM AND BASIC ISSUE ITEMS LISTS

## Section I. INTRODUCTION

## C-1. SCOPE.

This appendix lists components of end item and basic issue items for the S-280C/G Unshielded and S-280C/G Shielded Shelters to help you inventory items for safe and efficient operation.

## C-2. GENERAL.

The Components of the End Items and Basic Issue Items Lists are divided into the following sections:

*a. Section II. Components of End Item.* This listing is for informational purposes only, and is not authority to requisition replacements. These items are part of the end item, but are removed and separately packaged for transportation or shipment. As part of the end item, these items must be with the end item whenever it is issued or transferred between property accounts. Illustrations are furnished to assist you in identifying the items.

*b. Section III. Basic Issue Items.* These are the minimum essential items required to place the S-280C/G Unshielded and S-280C/G Shielded Shelters in operation, to operate them, and to perform emergency repairs. Although shipped separately packaged, BII must be with the shelters during operation and whenever they are transferred between property accounts. The illustrations will assist you with hard-to-identify items. This manual is your authorization to request-requisition replacement BII, based on TOE/MTOE authorization of the end item.

## C-3. EXPLANATION OF COLUMNS

The following provides an explanation of columns found in the tabular listings:

*a. Column (1) - Illustration Number (Illus Number).* This column indicates the number of the illustration in which the item is shown.

*b. Column (2) - National Stock Number.* Indicates the National Stock Number assigned to the item and will be used for requisitioning purposes.

*c. Column (3) - Description.* Indicates the Federal item name and, if required, a minimum description to identify and locate the item. The last line for each item indicates the FSCM (in parentheses) followed by the part number.

*d. Column (4) - Unit of Measure (U/M).* Indicates the measure used in performing the actual operation/maintenance function. This measure is expressed by a two-character alphabetical abbreviation (e.g., ea, in, pr).

*e. Column (5) - Quantity Required (Qty rqr).* Indicates the quantity of the item authorized to be used with/on the equipment.

**Section II. COMPONENTS OF END ITEM**

---

(1) ILLUS NO.	(2) NATIONAL STOCK NUMBER	(3) DESCRIPTION FSCM AND PART NUMBER	USABLE ON CODE	(4) U/M U/M	(5) QTY. REQ.
---------------------	---------------------------------	--	-------------------	-------------------	---------------------

---

NONE

Section III. BASIC ISSUE ITEMS

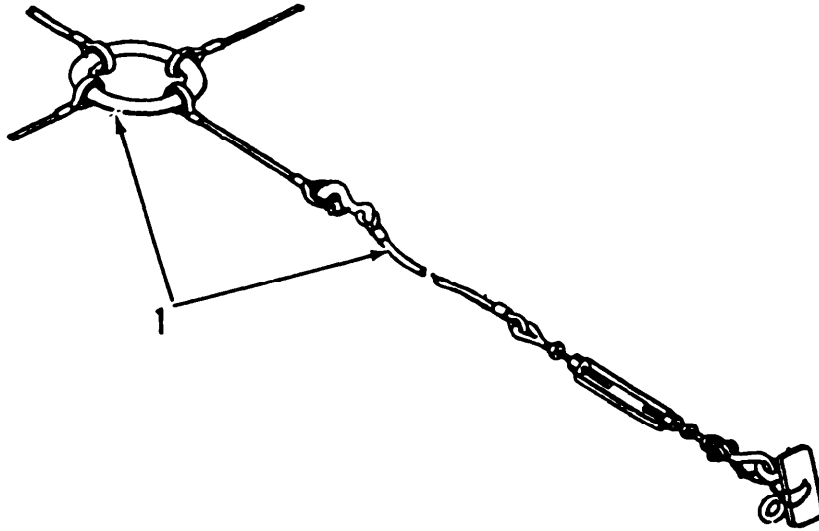

(1) ILLUS NO.	(2) NATIONAL STOCK NUMBER	(3) DESCRIPTION FSCM AND PART NUMBER	(4) USABLE ON CODE	(4) U/M U/M	(5) QTY. REQ.
1	3940-00-846-9858	SLING ASSEMBLY (81337) SC-D-36423		EA	1

**APPENDIX D**

**EXPENDABLE/DURABLE SUPPLIES AND MATERIALS LIST**

**Section I. INTRODUCTION**

**D-1. Scope.**

This appendix lists expendable/durable supplies and materials you will need to operate and maintain the S-280C/G Unshielded and S-280C/G Shielded Shelters. These items are authorized to you by CTA 50-970, Expendable/Durable Items (Except Medical, Class V, Repair Parts, and Heraldic Items), or CTA 8-100, Army Medical Department Expendable/Durable Items.

**D-2. EXPLANATION OF COLUMNS.**

a. Column (1) - Item number. This number is assigned to the entry in the listing.

b. Column (2) - Level. This column identifies the lowest level of maintenance that requires the listed item.

(Enter as applicable.)

- C - Operator
- O - Unit Maintenance
- F - Direct Support Maintenance
- H - General Support Maintenance

c. Column (3) - National Stock Number. This is the National Stock Number assigned to the item; use it to request or requisition the item.

d. Column (4) - Description. Indicates the Federal item name and, if required, a description to identify the item. The last line for each item indicates the Federal supply Code for Manufacturer (FSCM) in parentheses followed by the part number.

e. Column (5) - Unit of Measure (U/M). Indicates the measure used in performing the actual operation/maintenance function. This measure is expressed by a two-character alphabetical abbreviation (e.g., ea, in, pr). If the unit of measure differs from the unit of issue, requisition the lowest unit of issue that will satisfy your requirements.

**Section II. EXPENDABLE SUPPLIES AND MATERIALS LIST (cont)**

(1) ITEM NO.	(2) LEVEL	(3) NATIONAL STOCK NUMBER	(4) DESCRIPTION	(5) U/M
1	F	8415-00-634-5021	Gloves, JJ-G-451	pr
2	F		Caulking gun, 10-1/2"L x 3/8" Oval Tip	ea
3	F		Caulking cartridge (blank)	ea
4	F		Epoxy resin, Epic R1003	gl
5	F	<b>8040-00-222-9059</b>	Epoxy resin, Versamid 140	gl

Section II. EXPENDABLE SUPPLIES AND MATERIALS LIST (cont)

(1) ITEM NO.	(2) LEVEL	(3) NATIONAL STOCK NUMBER	(4) DESCRIPTION	(5) U/M
6	F		Container, unwaxed, 16 oz. UU-C-80611	ea
7	F	8020-00-689-5379	Roller Kit, H-R-550	ea
8	F	7510-00-266-6710	Tape, Masking	rl
9	F		Solvent, Toluene, TT-T-548	gl
10	F	6850-00-948-5853	Cloth, cotton	yd
11	F		Plywood, 1/2" thick 3' x 3'	sh
12	F		Polyethylene sheet	sh
13	F	5350-00-253-4393	Cloth, emery, coarse grit, 60 grit	sh
14	F	5350-00-161-9066	Cloth, emery, fine grit, 100 grit	sh
15	F	5350-00-192-5046	Sandpaper, 60 grit	sh
16	F		Rivet, countersunk, AK66H	ea
17	F		Fiber filled polyester resin	gl
18	F		Cloth, fiberglass	sh
19	F		Aluminum sheet, .040 in. thick QQ-A-250/11, 6061-T6	sh
20	F		Polyethylene sheet	sh
21	O	9150-01-260-2534	Lubricant, solid film	oz
22	O	9150-00-954-7422	Lubricant, solid film	qt
23	O		Paint, lusterless green No. 383, polyurethane, MIL-C-46168	gl
24	O		Paint, polyamide epoxy, MIL-C-22750	gl
25	O	5315-00-078-0112	Pin, headless, straight, MS16556-608	ea
26	O	8040-01-133-3304	Sealer, silicone , 138 RTV	tb
27	O		Gasket, silicone (81337) SM-C-564839	ft
28	O	8030-00-753-5005	Sealing compound, 6 oz., MIL-S-8802D	oz
29	O	7610-00-266-6714	Tape, polyethylene coated	rl
30	O	8040-00-078-9774	Adhesive, Sealastic, 732 RTV	tb
31	F		Core Material (81337) SM-C-595565	sh
32	F		Shield, EM (80063) SM-B-564670	rl
33	F		Tape (81337) SM-B-450436-1	ea

INDEX

**Subject** **Page**

**A**

**B**

**C**

**D**

Data, equipment . . . . .	1-3
Destruction of Army materiel to prevent enemy use . . . . .	1-1
Door assembly	
Adjust . . . . .	3-32
Assemble . . . . .	3-35
Install . . . . .	3-36
Disassemble . . . . .	3-35
Repair . . . . .	3-36
Replace . . . . .	3-34
Test . . . . .	3-31
Door brace assembly	
Assemble . . . . .	3-50
Disassemble . . . . .	3-49
Install . . . . .	3-50
Remove . . . . .	3-49
Door latch assembly	
Assemble . . . . .	3-44
Disassemble . . . . .	3-43
Repair . . . . .	3-45
Service . . . . .	3-43
Drain plug repair . . . . .	3-25
Drip moulding repair . . . . .	3-21

**E**

Emergency exit panel assembly	
Assemble . . . . .	3-41
Disassemble . . . . .	3-39
Install . . . . .	3-42
Remove . . . . .	3-39
Test . . . . .	3-38
Equipment characteristics, capabilities, and features . . . . .	1-2
Equipment description and data . . . . .	1-2
Expendable/durable materials . . . . .	D-1

**F**

Forklifting shelter . . . . .	3-2
-------------------------------	-----

**INDEX (cont)**

Subject	Page
<b>G</b>	
<b>H</b>	
Hand hold (roof) repair . . . . .	3-22
Hinge assembly	
Assemble . . . . .	3-29
Disassemble . . . . .	3-29
Install . . . . .	3-29
Remove . . . . .	3-29
Hold down assembly	
Repair . . . . .	3-59
Replace . . . . .	3-60
How-to use this manual . . . . .	iv
<b>I</b>	
Instruction plates . . . . .	1-4
<b>J</b>	
<b>K</b>	
Keeper assembly, replacement . . . . .	3-47
<b>L</b>	
Lifting and towing eye assembly	
Repair . . . . .	3-55
Replace . . . . .	3-55
Lifting shelter . . . . .	3-2
Lifting shelter onto truck . . . . .	3-3
Loading shelter onto truck or rail car . . . . .	3-61
Location and description of major components . . . . .	1-2
Lubrication . . . . .	3-1
<b>M</b>	
Maintenance allocation . . . . .	B-1
Maintenance forms and records . . . . .	1-1
Maintenance instructions	
Direct support . . . . .	4-2
General support . . . . .	5-1
Unit . . . . .	3-7
Marking, shelter . . . . .	1-3

INDEX (cont)

Subject	Page
<b>N</b>	
<b>O</b>	
Operational instructions . . . . .	2-1
Unusual conditions . . . . .	2-4
Usual conditions . . . . .	2-4
<b>P</b>	
Panel repair	
Delamination . . . . .	4-3
Small or shallow dent . . . . .	4-7
Small skin puncture or cut . . . . .	4-11
Large or deep dent . . . . .	4-9
Large single skin puncture or cut . . . . .	4-13
Temporary . . . . .	3-16
Plates, data, repair . . . . .	3-27
Preparation for shipment and storage . . . . .	1-1,3-61
Preventive Maintenance Checks and Services (PMCS), operator . . . . .	2-1
<b>Q</b>	
<b>R</b>	
Recessed step pan assembly	
Repair . . . . .	3-52
Replace . . . . .	3-52
References . . . . .	A-1
Repair parts . . . . .	3-1,4-1
Reporting equipment improvement recommendations . . . . .	1-1
RFI/EMI filter . . . . .	3-38
Rivet installation and removal . . . . .	3-8
Rivnut installation and removal . . . . .	3-12
<b>S</b>	
Safety, care and handling . . . . .	1-5
Securing shelter on 2-1/2 ton truck . . . . .	3-4
Service upon receipt . . . . .	3-1
Shield, EM . . . . .	3-31,38
Site requirements . . . . .	3-4
Skid assembly	
Repair . . . . .	3-56
Replace . . . . .	3-58
Storing shelter . . . . .	3-61



**INDEX (cont)**

<b>Subject</b>	<b>Page</b>
<b>T</b>	
T-latch assembly repair .....	3-24
Troubleshooting	
General support .....	4-1
Unit .....	3-5
Towing eye assembly	
Repair .....	3-54
Replace .....	3-54
<b>U</b>	
<b>V</b>	
<b>W</b>	
Warning plates .....	1-4
<b>X</b>	
<b>Y</b>	
<b>Z</b>	

**By Order of the Secretary of the Army:**

**CARL E. VUONO**  
*General, United States Army*  
*Chief of Staff*

**Official:**

**WILLIAM J. MEEHAN, II**  
*Brigadier General, United States Army*  
*The Adjutant General*

DISTRIBUTION :

To be distributed in accordance with DA Form 12-36-R, Operator, Unit, Direct Support and General Support Maintenance requirements for S-280A/G; S-280B/G; S-280C/G.

RECOMMENDED CHANGES TO EQUIPMENT TECHNICAL PUBLICATIONS



SOMETHING WRONG WITH THIS PUBLICATION?

FROM (PRINT YOUR UNIT'S COMPLETE ADDRESS)

PFC JOHN DOE  
COA, 3d ENGINEER BN  
FT. LEONARDWOOD, MD 63108

DATE SENT

PUBLICATION NUMBER

TM 10-5411-207-14

PUBLICATION DATE

18 SEPT 1989

PUBLICATION TITLE

Shelter, Electrical Equipment

BE EXACT. PIN-POINT WHERE IT IS

PAGE NO

6

PARA-GRAPH

2-1  
a

FIGURE NO

4-3

TABLE NO

125

line 20

IN THIS SPACE TELL WHAT IS WRONG AND WHAT SHOULD BE DONE ABOUT IT:

In line 6 of paragraph 2-1a the manual states the engine has 6 Cylinders. The engine on my set only has 4 Cylinders. Change the manual to show 4 Cylinders.

Callout 16 on figure 4-3 is pointing at a bolt. In key to figure 4-3, item 16 is called a shim - Please correct one or the other.

I ordered a gasket, item 19 on figure B-16 by NSN 2 910-00-762-3001. I got a gasket but it doesn't fit. Supply says I got what I ordered, so the NSN is wrong. Please give me a good NSN

PRINTED NAME, GRADE OR TITLE AND TELEPHONE NUMBER

JOHN DOE, PFC (268) 317-7111

SIGN HERE

JOHN DOE

DA FORM 2028-2  
1 JUL 79

PREVIOUS EDITIONS ARE OBSOLETE.

DRSTS-M Overprint 1, 1 Nov 80

PS -- IF YOUR OUTFIT WANTS TO KNOW ABOUT YOUR RECOMMENDATION MAKE A CARBON COPY OF THIS AND GIVE IT TO YOUR HEADQUARTERS

TEAR ALONG PERFORATED LINE

RECOMMENDED CHANGES TO EQUIPMENT TECHNICAL PUBLICATIONS



THEN... JOT DOWN THE DOPE ABOUT IT ON THIS FORM. CAREFULLY TEAR IT OUT. FOLD IT AND DROP IT IN THE MAIL!

**SOMETHING WRONG WITH THIS PUBLICATION?**

FROM: (PRINT YOUR UNIT'S COMPLETE ADDRESS)

DATE SENT

PUBLICATION NUMBER  
TM 10-5411-207-14

PUBLICATION DATE  
18 SEPT 1989

PUBLICATION TITLE  
Shelter, Electrical Equipment

BE EXACT PIN-POINT WHERE IT IS

PAGE NO	PARA-GRAPH	FIGURE NO	TABLE NO

IN THIS SPACE TELL WHAT IS WRONG AND WHAT SHOULD BE DONE ABOUT IT:

*(This area is currently blank for user input.)*

PRINTED NAME, GRADE OR TITLE, AND TELEPHONE NUMBER

SIGN HERE

DA FORM 2028-2  
1 JUL 79

PREVIOUS EDITIONS ARE OBSOLETE.  
DRSTS-M Overprint 2, 1 Nov 80.

P.S.--IF YOUR OUTFIT WANTS TO KNOW ABOUT YOUR RECOMMENDATION MAKE A CARBON COPY OF THIS AND GIVE IT TO YOUR HEADQUARTERS

TEAR ALONG PERFORATED LINE

FILL IN YOUR  
UNIT'S ADDRESS

FOLD BACK

DEPARTMENT OF THE ARMY

OFFICIAL BUSINESS  
PENALTY FOR PRIVATE USE \$300

COMMANDER  
U S ARMY TROOP SUPPORT COMMAND  
ATTN: AMSTR-MCTS  
4300 GOODFELLOW BOULEVARD  
ST. LOUIS, MO 63120-1798

TEAR ALONG PERFORATED LINE

# The Metric System and Equivalents

## Linear Measure

1 centimeter = 10 millimeters = .39 inch  
 1 decimeter = 10 centimeters = 3.94 inches  
 1 meter = 10 decimeters = 39.37 inches  
 1 dekameter = 10 meters = 32.8 feet  
 1 hectometer = 10 dekameters = 328.08 feet  
 1 kilometer = 10 hectometers = 3,280.8 feet

## Weights

1 centigram = 10 milligrams = .15 grain  
 1 decigram = 10 centigrams = 1.54 grains  
 1 gram = 10 decigrams = .035 ounce  
 1 dekagram = 10 grams = .35 ounce  
 1 hectogram = 10 dekagrams = 3.52 ounces  
 1 kilogram = 10 hectograms = 2.2 pounds  
 1 quintal = 100 kilograms = 220.46 pounds  
 1 metric ton = 10 quintals = 1.1 short tons

## Liquid Measure

1 centiliter = 10 milliliters = .34 fl. ounce  
 1 deciliter = 10 centiliters = 3.38 fl. ounces  
 1 liter = 10 deciliters = 33.81 fl. ounces  
 1 dekaliter = 10 liters = 2.64 gallons  
 1 hectoliter = 10 dekaliters = 26.42 gallons  
 1 kiloliter = 10 hectoliters = 264.18 gallons

## Square Measure

1 sq. centimeter = 100 sq. millimeters = .155 sq. inch  
 1 sq. decimeter = 100 sq. centimeters = 15.5 sq. inches  
 1 sq. meter (centare) = 100 sq. decimeters = 10.76 sq. feet  
 1 sq. dekameter (are) = 100 sq. meters = 1,076.4 sq. feet  
 1 sq. hectometer (hectare) = 100 sq. dekameters = 2.47 acres  
 1 sq. kilometer = 100 sq. hectometers = .386 sq. mile

## Cubic Measure

1 cu. centimeter = 1000 cu. millimeters = .06 cu. inch  
 1 cu. decimeter = 1000 cu. centimeters = 61.02 cu. inches  
 1 cu. meter = 1000 cu. decimeters = 35.31 cu. feet

## Approximate Conversion Factors

To change	To	Multiply by	To change	To	Multiply by
inches	centimeters	2.540	ounce-inches	newton-meters	.007062
feet	meters	.305	centimeters	inches	.394
yards	meters	.914	meters	feet	3.280
miles	kilometers	1.609	meters	yards	1.094
square inches	square centimeters	6.451	kilometers	miles	.621
square feet	square meters	.093	square centimeters	square inches	.155
square yards	square meters	.836	square meters	square feet	10.764
square miles	square kilometers	2.590	square meters	square yards	1.196
acres	square hectometers	.405	square kilometers	square miles	.386
cubic feet	cubic meters	.028	square hectometers	acres	2.471
cubic yards	cubic meters	.765	cubic meters	cubic feet	35.315
fluid ounces	milliliters	29.573	cubic meters	cubic yards	1.308
pints	liters	.473	milliliters	fluid ounces	.034
quarts	liters	.946	liters	pints	2.113
gallons	liters	3.785	liters	quarts	1.057
ounces	grams	28.349	liters	gallons	.264
pounds	kilograms	.454	grams	ounces	.035
short tons	metric tons	.907	kilograms	pounds	2.205
pound-feet	newton-meters	1.356	metric tons	short tons	1.102
pound-inches	newton-meters	.11296			

## Temperature (Exact)

°F	Fahrenheit temperature	5/9 (after subtracting 32)	Celsius temperature	°C
----	------------------------	----------------------------	---------------------	----

**PIN: 067017-002**